

**electroair**  
ELECTRONIC IGNITION SYSTEMS

***EIS-41000***  
***Instructions for Continued***  
***Airworthiness***  
***Engine STC# SE04577CH***

Original Issue: Level 00, 14 - December – 2022  
Current Revision: Level 00, 14 – December – 2022

***Electroair***  
***5097 Williams Lake Road***  
***Waterford, MI 48329 U.S.A.***  
***Ph: 248-674-3433 Fax: 248-674-4231***  
***Email: sales@electroair.net***

## ***Glossary and Abbreviations:***

- AD(s) – airworthiness directive(s)
- AFM – aircraft flight manual
- AFMS – aircraft flight manual supplement
- Airframe Component – Component of EIS that attaches directly to the engine.
- ALS – aircraft limitations section
- AML – approved model list
- BTDC – before top dead center
- CFR – code of federal regulations
- CHT – Cylinder Head Temperature
- CSTW – crankshaft trigger wheel
- EIS – electronic ignition system
- Engine Component – Component of EIS that attaches directly to the engine.
- FAA – federal aviation administration
- IAW – In accordance with
- ICA – Instructions for Continued Airworthiness
- LOPC – Loss Of Power Control
- MAG -- magneto
- MAP – manifold absolute pressure
- May/Should – an optional requirement
- MTH – mag timing housing
- MEL – Minimum Equipment List
- Must/Shall – a mandatory requirement
- POH – Pilot Operating Handbook
- RPM – revolutions per minute
- STC – supplemental type certificate
- TDC – top dead center

## Revision Log

Revision	Pages Affected	Date of Revision	Description of Revision	Approved by	Date of Approval
00	All	12/14/2022	Project # ST10697CH-E		

Electroair has a process in place for updating designs and issuing Service updates. Service updates that affect ICA will initially be posted by a Service Bulletin and then updated within the ICA as determined by both Electroair and the FAA, or as required by regulations. All updated ICA (including Service Bulletins) will be available at [www.electroair.net](http://www.electroair.net) or upon request.

### List of Effective Pages

Section	Page	Section Status	Revision Level
Title	1	Original	00
Glossary and Abbreviations	2	Original	00
Revision Log	3	Original	00
Table of Contents	4	Original	00
Table of Figures	4	Original	00
Chapter 1	5-7		
Section 01-00-00	5-6	Original	00
Section 01-20-00	6	Original	00
Section 01-25-00	6	Original	00
Section 01-72-00	6-7	Original	00
Chapter 4	8		
Section 04-00-00	8	Original	00
Chapter 5	9-18		
Section 05-00-00	9	Original	00
Section 05-10-10	10-11	Original	00
Section 05-20-10	12-13	Original	00
Section 05-20-30	14	Original	00
Section 05-50-10	15-18	Original	00
Chapter 8	19		
Section 08-00-00	19	Original	00
Chapter 20	20		
Section 20-00-00	20	Original	00
Chapter 72 (R)	21		
Section 72(R)-00-00	21	Original	00
Chapter 98	22-25		
Section 98-00-00	22-25	Original	00
Appendix A – Installation Manual	26	Original	00

# Table of Contents

- GLOSSARY AND ABBREVIATIONS:..... 1**
- REVISION LOG..... 3**
- TABLE OF CONTENTS..... 4**
- TABLE OF FIGURES..... 4**
- CHAPTER 1..... 5**
  - SECTION 01-00-00: INTRODUCTION..... 5
  - SECTION 01-20-00: OPERATION..... 6
  - SECTION 01-25-00 STRUCTURAL FASTENERS..... 6
  - SECTION 01-72-00: ENGINE INTERFACE..... 6
- CHAPTER 4..... 8**
  - SECTION 04-00-00: AIRWORTHINESS LIMITATIONS..... 8
- CHAPTER 5..... 9**
  - SECTION 05-00-00: GENERAL INFORMATION & PRECAUTIONARY STATEMENTS..... 9
  - SECTION 05-10-10: TIME LIMITS, ENGINE COMPONENTS..... 10
  - SECTION 05-20-10: SCHEDULED MAINTENANCE CHECKS, ENGINE COMPONENTS..... 12
  - SECTION 05-20-30: SPECIAL INSPECTIONS, ENGINE COMPONENTS..... 14
  - SECTION 05-50-10: UNSCHEDULED MAINTENANCE CHECKS/TROUBLESHOOTING, ENGINE COMPONENTS..... 15
- CHAPTER 8..... 19**
  - SECTION 08-00-00: WEIGHT AND BALANCE INFORMATION..... 19
- CHAPTER 20..... 20**
  - SECTION 20-00-00: STANDARD PRACTICES – ENGINE..... 20
- CHAPTER 72 (R)..... 21**
  - SECTION 72(R)-00-00: GENERAL..... 21
- CHAPTER 98..... 22**
  - SECTION 98-00-00: WIRING DIAGRAMS FOR EIS-41000 SERIES KITS (REFERENCE ONLY)..... 22
- APPENDIX A – INSTALLATION MANUAL..... 26**

## Table of Figures

- FIGURE 1: TYPICAL EIS-41000 KIT..... 5
- FIGURE 2: WIRING DIAGRAM FOR EIS-41000, EIS-41000IC, EIS-41000LH, EIS-41000LHIC, EIS-41000T, EIS-41000TIC, EIS-41000TLH, & EIS-41000TLHIC..... 21
- FIGURE 3: WIRING DIAGRAM FOR EIS-41000, EIS-41000IC, EIS-41000LH, EIS-41000LHIC, EIS-41000T, EIS-41000TIC, EIS-41000TLH, & EIS-41000TLHIC..... 22
- FIGURE 4: SINGLE ENGINE, SINGLE EIS POWER CONNECTION..... 23
- FIGURE 5: SINGLE ENGINE, DUAL EIS ELECTRICAL POWER CONNECTIONS..... 23
- FIGURE 6: SINGLE ENGINE, DUAL EIS BACKUP ALTERNATOR CONNECTIONS..... 23
- FIGURE 7: TWIN ENGINE, DUAL EIS, SINGLE ELECTRICAL SYSTEM POWER CONNECTIONS..... 24
- FIGURE 8: TWIN ENGINE, DUAL EIS, SINGLE ELECTRICAL SYSTEM POWER CONNECTIONS..... 25

# Chapter 1

## Section 01-00-00: Introduction

These are the accepted Instructions for Continued Airworthiness for the modification performed in accordance with the Electroair EIS-41000 Electronic Ignition System Engine STC# SE04577CH. All references to the EIS-41000 in this document will refer to the Electroair EIS-41000 Electronic Ignition System Series Kits (EIS-41000(T)(LH)(IC)) and related components as specified in these Instructions for Continued Airworthiness (ICA). STC Permission Letters and the ICA will be supplied to the owner/operator of the STCs at the time of completion. Subsequent accepted changes to the ICA will be available to owners and operator of the STCs.

The EIS-41000 Electronic Ignition System can be installed as a replacement for a single magneto, or two EIS-41000 Electronic Ignition Systems can be installed to replace both magnetos, creating a dual electronic ignition system. When two EIS-41000 systems are installed in accordance with the Installation Manual, IM EIS-41000, each ignition system will be completely independent of the other, using separate trigger mechanisms and control devices to operate their respective set of spark plugs. There shall be no common connection between the two ignition systems that in the event of one ignition system failing, would cause the other ignition system to fail as well.

A single EIS-41000 series kit consists of the following components: Controller (EA-20000), Coil Pack (EA-2000), Spark Plug Wires (EA-4000), Wire Harness (EA-22000(T)), and Trigger Mechanism (EA-3000(LH)(IC), EA-24000(LH), or EA-9000A).



Figure 1: Typical EIS-41000 Kit

The EIS-41000 Electronic Ignition System performs its function by delivering energy generated by the coil pack to each spark plug attached to the system. This high voltage from the coil pack creates a high intensity, long duration spark which can ignite a wide range of fuel/air mixtures inside of the cylinder. The EIS-41000 is also able to vary the ignition timing (spark event) during the combustion cycle to more closely have the peak

pressure as a result of combustion occur at an optimal range for a piston engine. The adjustment of ignition timing is based on MAP inside the engine. The combination of a high energy spark and variable timing permits more an efficient operation of the engine.

This ICA is intended to supplement the aircraft's maintenance manual when the Electroair Electronic Ignition System Engine STC# SE04577CH is installed. The information, procedures, requirements, and limitations contained in this ICA for this type design change supersedes the information, procedures, requirements and limitations contained in the aircraft's maintenance manual when this type design change is installed.

### **Section 01-20-00: Operation**

The system is operated in accordance with AFMS EIS-41000 REV09 or later FAA approved revisions.

### **Section 01-25-00 Structural Fasteners**

Information required for fastener types, torque values, identification and discard recommendations are located in the installation manual IM EIS-41000 REV16 or later FAA approved revision. The installation manual is also located in Appendix A of this document.

### **Section 01-72-00: Engine Interface**

This installation differs from a conventional magneto installation in the following ways:

1. System requires coil pack and controller to be mounted to the airframe, this differs from a conventional installation where these items are internal to the magneto.
2. System requires a trigger mechanism consisting of a magnetic pickup and trigger wheel which replaces the points found on a conventional magneto.
3. System requires the use of spark plug leads that meet the requirements of a high energy ignition pulse. Use of conventional magneto leads appropriate for magneto system are not appropriate for this system.
4. In order to accommodate the higher energy ignition pulse, the spark plug gap has been increased to an optimal level for the Electroair system. Switches regulate power to the controller (see 01-00-00 for description).
5. Separate circuit protection in the form of circuit breaker/fuse or other fusible link device is required for the coil pack system (see 01-00-00 for description).
6. Controller interfaces with engine manifold vacuum obtained from a connected manifold line to calculate ignition timing (see Appendix A for detail).
7. Timing is based upon the signal from the MTH being fixed to the accessory case or from CSTW attached to the crankshaft in order to provide crankshaft position and speed. Unlike conventional magneto systems, no mechanical timing adjustment is possible - the controller determines ignition timing based on crankshaft position, RPM, and manifold vacuum. The Installation manual, IM EIS-

41000 REV16 or later FAA approved revision, contains specific details of this operation. The installation manual is also located in Appendix A of this document.

## **Chapter 4**

### **Section 04-00-00: Airworthiness Limitations**

The Airworthiness Limitations Section is FAA approved and specifies maintenance required 14 CFR §§43.16 and 91.403 of the Federal Aviation Regulations unless an alternative program has been FAA approved.

There are no specific airworthiness limitations for the engine STC# SE04577CH.

FAA Approved: \_\_\_\_\_

Date: \_\_\_\_\_



## Chapter 5

### Section 05-00-00: General Information & Precautionary Statements

- Read this entire document before starting any processes listed within this document. If there are any questions or concerns please contact Electroair before starting. (248-674-3433 or [sales@electroair.net](mailto:sales@electroair.net))
- This ICA applies to installation of one or two (dual) Electroair electronic ignition systems. If dual Electroair electronic ignition systems are installed, then each inspection shall be performed twice, one for each, separate ignition system.
- Note that the engine STC is paired with an Aircraft STC which has its own ICA document #ICA EIS-41000 to maintain the continued airworthiness for that design change.
- If an EIS is improperly installed, or maintained; the EIS, the aircraft, the engine, or the installer could be seriously damaged.
- Always use appropriate work and safety practices.
- Spark plug leads shall be disconnected from the ignition system before inspection.
- DO NOT NEGLECT the required maintenance of the remaining magneto or pressurize magneto (if installed).
- For the latest up to date information refer to [www.electroair.net](http://www.electroair.net) (ICA, AML, Installation Manual, AFMS, etc.)
- For abnormal operation, for ignition systems that have a suspected failure, refer to the Section 05-50-10 of this document for Unscheduled Maintenance Checks. You can also contact Electroair for additional assistance. (248-674-3433 or [sales@electroair.net](mailto:sales@electroair.net))
- For service bulletins, or other product notes, review Electroair website ([www.electroair.net](http://www.electroair.net)).
- Refer to the installation manual for required tooling. The installation manual can be found online at [http://electroair.net/pdfs/EIS\\_41000\\_Installation\\_Manual.pdf](http://electroair.net/pdfs/EIS_41000_Installation_Manual.pdf). Note: Installation of the EIS system does NOT eliminate the requirement to comply with applicable airworthiness directives (ADs).
- For ordering or questions about replacement parts, please contact Electroair. (248-674-3433 or [sales@electroair.net](mailto:sales@electroair.net))
- This ICA is for the Engine Components of the EIS-41000. For Airframe components, refer to ICA EIS-41000 revision 10 or later FAA approved revision.

## Section 05-10-10: Time Limits, Engine Components

1. **General:** This Chapter contains the time limit intervals for the engine components from the EIS-41000 installation. This chapter is to be added to the approved scheduled inspection for the aircraft.
2. Engine Components with Time Limits:
  - a. **Spark Plug Wire Assemblies:** The spark plug wire assemblies shall be replaced after 1,000 hours of operation or after five calendar years of installation.
    - i. Use p/n EA-4000REM Spark Plug Wire Kit if using REM style spark plugs.
    - ii. Use p/n EA-4000RHMRHB Spark Plug Wire kit if using either RHM or RHB style spark plugs.
    - iii. One spark plug wire kit replaces one spark plug wire assembly; order the correct number of spark plug wire kits for the number of spark plug wire assemblies that need to be replaced.
    - iv. Assembly instructions should be included with the Spark Plug Wire Kit, otherwise, refer to the installation manual (Appendix A), IM EIS-41000, REV 16, or later approved revisions for instructions on fabricating the spark plug wire assemblies.
    - v. It is recommended that the old spark plug wire assemblies be kept for reference until the new wires are completely installed.
    - vi. Make sure an audible snap is heard (and felt) when installing the spark plug wires on to the coil pack.
    - vii. Do not over-torque the spark plug nuts on to the spark plugs. For REM style plugs, use a torque value of 90-95 in-lbs; for RHB & RHM style plugs, use a torque value of 110-120 in-lbs.
  - b. **Mag Timing Housing (MTH):** The Mag Timing Housing is installed as a replacement for one of the magnetos and provides engine position and RPM information to the Electronic Ignition System. Two MTHs may be installed in the case of dual electronic ignition systems. Instructions apply to either the one MTH or both MTHs (if installed).
    - i. Replace this unit at 2,500 hours after installation.
    - ii. Verify part number of unit installed on the engine.
      1. Use p/n EA-3000 to replace a direct drive magneto.
      2. Use p/n EA-3000IC to replace an impulse coupled magneto.
      3. Use p/n EA-3000LH to replace a direct drive magneto in a counter-rotating engine.
      4. Use p/n EA-3000LHIC to replace an impulse coupled magneto in a counter-rotating engine.
      5. Use p/n EA-24000 to replace single-drive dual magneto.
      6. Use p/n EA-24000LH to replace counter-rotating single-drive dual magneto.
    - iii. Assembly instructions should be included with the replacement MTH, otherwise, refer to the installation manual (Appendix A), IM

- EIS-41000, REV 16, or later approved revisions for instructions on installing the MTH.
- iv. Removal of the old MTH is performed by following the installation instructions in reverse order.
  - v. When installing the new MTH, confirm that the engine is set to zero-degree TDC, on number one cylinder.
  - vi. Signal wire IS NOT to be coupled, zip tied to, or otherwise attached to any high energy wires such as a starter wire or spark plug wires. This can cause the signal from the MTH to be interrupted.
- c. **Crank Shaft Trigger Wheel (CSTW) Sensor:** If installed – Note, this is not a common installation, except for single-drive dual magneto replacement.
- i. Replace the CSTW Sensor at engine overhaul or at any time the engine case is opened for other maintenance.
  - ii. Use p/n EA-9070 for a replacement sensor.
  - iii. Assembly instructions should be included with the replacement sensor, otherwise, refer to the installation manual (Appendix A), IM EIS-41000, REV 16, or later approved revisions for instructions on installing the sensor.
  - iv. Removal of the old sensor is performed by following the installation instructions in reverse order.
  - v. Signal wire IS NOT to be coupled, zip tied to, or otherwise attached to any high energy wires such as a starter wire or spark plug wires. This can cause the signal from the sensor to be interrupted.

## Section 05-20-10: Scheduled Maintenance Checks, Engine Components

1. **General:** This Chapter contains the time limit intervals for the Engine Components from the EIS-41000 series installation. This chapter is to be added to the approved scheduled inspection for the aircraft. If any part of the installation appears to be functioning improperly, consult Section 05-50-10 for Unscheduled Maintenance and Troubleshooting. If a major component is damaged or continues to malfunction, the component in question should be returned to the manufacturer for replacement.
2. **Engine Components with Scheduled Maintenance Checks:** These inspections are to be performed at the aircraft's Annual Inspection or at the aircraft's 100-hour inspection.
  - a. **Mag Timing Housing (MTH):** The Mag Timing Housing is installed as a replacement for one of the magnetos and provides engine position and RPM information to the Electronic Ignition System. Two MTHs may be installed in the case of dual electronic ignition systems. Instructions apply to either the one MTH or both MTHs (if installed).
    - i. Inspect the "gasket" area on the MTH. Ensure no oil leaks are present at the gasket area. If a new gasket is required, order Electroair part number EA-001J.
    - ii. Inspect MTH harness connection to main wiring harness and verify that the connector is securely in place.
    - iii. Inspect MTH for oil seal failures.
      1. Remove MTH cover.
      2. Inspect for oil pooling – this indicates the oil seal has failed. If oil seal has failed, MTH MUST be replaced. NOTE: a thin film of oil does not indicate a failure. If MTH is to be replaced, verify the correct part number MTH is ordered (old unit will be labelled with correct part number).
      3. If MTH passes inspection, replace the cover in the same orientation it was removed. For units that have a yellow triangle on the MTH cover, the yellow triangle shall point towards the magnetic pick-up.
      4. Note: MTH is not field serviceable or repairable.
  - b. **Spark Plug Wires:** In general, inspect all spark plug wires for general condition, proper spacing (distance of ¼" apart where practical) and no connection to sensitive signal wires. Review logbooks to determine when spark plug wires were last replaced and verify the time limit on the spark plug wires has not been exceeded.
    - i. Inspect all spark plug wires for exterior damage such as cuts in the silicone, chaffing, or evidence of arcing and/or burn marks. Replace wire if any of this damage is evident.
    - ii. If inspection shows no problems, move on to next inspection item; if wire or wires need to be replaced, then follow the next steps:
    - iii. Use p/n EA-4000REM Spark Plug Wire Kit if using REM style spark plugs.

- iv. Use p/n EA-4000RHMRHB Spark Plug Wire kit if using either RHM or RHB style spark plugs.
  - v. One spark plug wire kit replaces one spark plug wire assembly; order the correct number of spark plug wire kits for the number of spark plug wire assemblies that need to be replaced.
  - vi. Assembly instructions should be included with the Spark Plug Wire Kit, otherwise, refer to the installation manual (Appendix A), IM EIS-41000, REV 16, or later approved revisions for instructions on fabricating the spark plug wire assemblies.
  - vii. It is recommended that the old spark plug wire assemblies be kept for reference until the new wires are completely installed.
  - viii. Make sure an audible snap is heard (and felt) when installing the spark plug wires on to the coil pack. If testing is required, use standard practices for testing spark plug wires.
  - ix. Do not over-torque the spark plug nuts on to the spark plugs. For REM style plugs, use a torque value of 90-95 in-lbs; for RHB & RHM style plugs, use a torque value of 110-120 in-lbs.
- c. **Spark Plugs:** Spark plugs were not provided as part of the EIS-41000 kit, and therefore not subject to this ICA, however, we recommend removing and inspecting all spark plugs I.A.W. spark plug manufacturer's inspection process, ICA, or other applicable document.
- i. Replace any defective spark plugs.
  - ii. Verify that the spark plug gap is between 0.028" – 0.038" gap; correct as necessary. Refer to Appendix A for detail.
  - iii. If using Electroair branded spark plugs, check the resistance of the spark plug's center conductor. A passing value is 5,000 ohms or less. Plugs that have a resistance higher than 5,000 ohms shall be replaced.
  - iv. Verify correct spark plug part number is being used for the engine.
- d. **Post Inspection:** After inspections are complete, verify the operation of the EIS system by performing a normal start, engine run-up and ignition check per the aircraft's Flight Manual or Pilot's Operating Handbook AND the AFMS EIS-41000, REV 09 or later FAA approved revisions. Note: Update aircraft logbooks as required and return aircraft to service.
3. Special Tools, Removal and Re-Installation of Engine Components:
- a. No special tools are required to work on an EIS-41000 system.
  - b. For removal of any Engine Component, follow the IM EIS-41000 (Appendix A) in reverse order.
  - c. For re-installation of any engine component, follow the instructions that accompanied the replacement part or refer to the installation manual located in Appendix A of this document. Installation Manuals are also available to [www.electroair.net](http://www.electroair.net).
  - d. After reinstallation, verify the operation of the EIS system by performing a normal start, engine run-up and ignition check per the aircraft's Flight Manual or Pilot's Operating Handbook AND the AFMS EIS-41000, REV 09 or later FAA approved revisions.

## Section 05-20-30: Special Inspections, Engine Components

1. **General:** This section contains requirements for special inspections of the Engine Components of the EIS-41000. Conditions may arise from incidents or accidents that warrant additional, special inspection of major components of the Electroair EIS-41000 system. A Special Inspection is required if the aircraft is subject to total immersion in water, lightning strike, prop strike or sudden stoppage of the engine. If any part of the installation appears to be functioning improperly, refer to Section 05-50-10 for Unscheduled Maintenance and Troubleshooting of the system. If a major component in question is damaged or continues to malfunction, the component in question should be returned to the manufacturer for replacement. Removal and installation instructions can be found in the Installation manual located in Appendix A of this document.
2. Total Immersion in Water:
  - a. **Mag Timing Housing (MTH):** No inspection required. Unit is required to be replaced.
  - b. **Spark Plug Wires:** Inspect spark plug wires I.A.W. Section 05-20-10 of this ICA. Remove and replace any damaged spark plug wires.
  - c. **Crank Shaft Trigger Wheel (CSTW):** Replace magnetic sensor. Use p/n: EA-9070. Inspect bracket and replace if damaged.
3. Lightning Strikes:
  - a. **Mag Timing Housing (MTH):** Inspect MTH I.A.W. Section 05-20-10 of this ICA. Replace unit if necessary
  - b. **Spark Plug Wires:** Inspect spark plug wires I.A.W. Section 05-20-10 of this ICA. Remove and replace any damaged spark plug wires.
  - c. **Crank Shaft Trigger Wheel (CSTW):** Replace magnetic sensor. Use p/n: EA-9070. Inspect bracket and replace if damaged.
4. Prop Strike/Sudden Engine Stoppage:
  - a. **Mag Timing Housing (MTH):** No inspection required. Unit is required to be replaced.
  - b. **Spark Plug Wires:** Inspect spark plug wires I.A.W. Section 05-20-10 of this ICA. Remove and replace any damaged spark plug wires.
  - c. **Crank Shaft Trigger Wheel (CSTW):** Replace magnetic sensor. Use p/n: EA-9070. Replace bracket.

## Section 05-50-10: **Unscheduled Maintenance Checks/Troubleshooting, Engine Components**

1. **General:** This section contains requirements for unscheduled maintenance checks and troubleshooting of the Engine Components of the EIS-41000. Conditions may arise from time to time that warrant additional, unscheduled inspection of major components of the Electroair EIS-41000 series system. These conditions arise out of a change in normal engine operation and can result in a poorly performing engine. This section will identify some of those conditions requiring unscheduled maintenance checks as related to the engine components of the EIS-41000 system and is to be used if the Electroair system is suspected to be the fault or appears to be functioning improperly. If a major component in question is damaged or continues to malfunction, the component in question should be returned to the manufacturer for replacement.
2. **Ignition Specifications for Reference:** These specifications are not required to be checked on a periodic basis but do offer a good diagnostic tool for resolving conditions that result in a poorly running engine.
  - a. **Magnetic Sensor Resistance:** Electroair has provided two different types of sensors for the EIS kits. Both sensors function in the same way. Both sensors have three wires; resistance measurement is required over two of the wires.
    - i. **Sensor #1:** A red and black wire should be visible going into the three-way connector. Locate the sensor pin location for each wire. Measure the resistance between the red & black wire at the sensor pins. A normal reading is between 600 & 800 ohms and remains steady with movement of the wire harness.
    - ii. **Sensor #2:** A white and black wire should be visible going to the three-way connector. Locate the sensor pin location for each wire. Measure the resistance between the white and black wire at the sensor pins. A normal reading is between 900 & 1100 ohms and remains steady with movement of the wire harness.
  - b. **Sensor Gap in the MTH:** Remove the back cover of the MTH and you will find a 60 minus 2 tooth trigger wheel and a magnetic sensor position over the trigger wheel. The air gap for the sensor relative to the teeth on the trigger wheel is 0.008" – 0.015" (factory setting is 0.011").
  - c. **Spark Plug Wire Resistance:** Electroair has sold two different types of spark plug wires, easily distinguished by its color. Resistance values are given in ohms per foot of wire.
    - i. **Blue Wire/EA-4090:** Resistance = 350ohm/ft (+/- 10%).
    - ii. **Red Wire/EA-4091:** Resistance = 5,700ohm/ft (+/- 10%).
3. **Condition #1: Higher than normal RPM drops During Ignition Check:** The RPM drop when performing an ignition check is greater than 40RPM when running on the Electroair Ignition System alone.
  - a. Engine running smooth and experiencing a high RPM drop on EIS alone.
    - i. This is an indication of an ignition timing problem.

- ii. Verify that ignition check was performed to engine manufacturer's recommendations and RPM levels.
  - iii. Record RPM drops for both ignitions and record RPM rise during mixture-idle shutdown (no rise indicates an induction leak).
  - iv. Rotate engine to TDC on #1 cylinder. Note: Engine timing marks can be incorrect.
  - v. Verify that MTH has been installed correctly using the lockpin (supplied with the kit) and the engine at TDC on #1 cylinder. Pin should drop right in.
  - vi. With the engine at TDC on #1 cylinder, visually inspect trigger wheel in MTH (or on CSTW as practical) and make sure the trailing edge of the 11<sup>th</sup> tooth, past the two missing (indexing) teeth is positioned under the center of the sensor. Loosen hold down MTH hold down clamps and adjust as necessary).
  - vii. Verify that there are no induction leaks. Perform induction leak check if not sure. Correct induction leak if discovered.
  - viii. Inspect MTH for oil seal failure (see Section 05-20-10). Replace MTH if necessary.
  - ix. Verify correct spark plug part number is being used for the engine.
  - x. If problem persists, contact the factory.
- b. Engine running rough and experiencing a high RPM drop on the EIS alone.
- i. This is an indication of one or more cylinders (depending on the magnitude of RPM drop) misfiring.
  - ii. Verify that ignition check was performed to the engine manufacturer's recommendations and RPM levels.
  - iii. Examine CHT and EGT data if available. Anomalies in temperature data should be investigated as this suggests misfiring in a given cylinder.
  - iv. If low CHT (or high EGT) is noticeable on one or two of the cylinders when running on just one EIS, inspect the plugs and plug wires for misfiring.
    - 1. Reference Section 05-20-10 for inspecting spark plug wires.
    - 2. Make sure the spark plug wire spring is reaching down far enough in the spark plug well to get at least half compression when installed. Correct plug wire and spring for correct depth.
    - 3. Inspect spark plug wire spring for fretting (drag thumb nail along wire and feel for roughness). If fretting is evident, this indicates a poor connection between the wire and spring or between the spring and the center conductor of the spark plug. Replace spring.
    - 4. Inspect plug wire gasket for good seal with the top of the spark plug. If gasket is no longer making a good seal or appears torn or damaged, replace gaskets.
      - a. P/N EA-4041 for REM style spark plugs.



- b. P/N EA-4141 for RHM/RHB style spark plugs.
  - v. If temperature data is not available, inspect all spark plugs and spark plug wires related to suspected EIS unit for misfiring I.A.W. Section 05-20-10 and repeat steps iv. 1-4 (above) for all spark plugs and plug wires.
  - vi. Verify spark plug wire resistance against the standard established in Section 05-50-10-02. Remove and replace as necessary.
  - vii. Verify correct spark plug part number is being used for the engine.
  - viii. If problem persists, contact the factory.
- 4. **Condition #2 - Engine not running on EIS:** This will typically present when performing a ground run-up of the aircraft and an ignition check. When selecting EIS alone, the engine stops developing power and shuts down, indicating that no ignition event is occurring.
  - a. Check the resistance values of the sensor at the MTH or CSTW. If the resistance reading is out of range, or reads zero or infinite, the sensor needs to be replaced.
    - i. MTH Replacement Sensor Part Number: EA-3050.
    - ii. CSTW Replacement Sensor Part Number: EA-9070
  - b. Verify that MTH or CSTW sensor is plugged into the harness.
  - c. Verify that all grounds, including engine ground, have a competent pathway to the battery ground.
  - d. If problem persists, contact the factory.
- 5. **Condition #3 – EIS dropping off-line or is intermittent.** This is indicative of a magnetic sensor that is in the process of failing. Follow the same steps as Condition #2.
- 6. **Condition #4 – Engine is experiencing a high altitude and/or high power miss.** This is indicative of a plug or plug wire beginning to fail or have an arch over condition. Follow the steps in Condition #1(b). In particular, inspect the inner well of the spark plugs for carbon tracking – plugs with carbon tracking in the inner ceramic well are experiencing some missing during engine operation.
- 7. **Condition #5 – Engine is surging during ground and/or air operations.** This is indicative of the Electroair system reading a variable MAP. Variable MAP can be caused by a number of discrepancies within the engine itself, and should cause the technician to look broadly at the engine operation.
  - a. Make sure MAP connection to the ignition controller is secure and not leaking.
  - b. Record RPM drops of both ignitions; note any drops that are out of specification. Record RPM rise during mixture-idle shutdown.
    - i. No RPM rise during shutdown is indicative of an induction leak.
    - ii. Perform induction leak check and correct any leaks found.
    - iii. Verify that induction seals are seated in place correctly. Repair as necessary.
  - c. Inspect spark plugs and plug wires for intermittent arch-over or leaking. Follow steps listed in Condition #1, b, i-vii.

- d. Inspect installation of MTH. Verify that the hold-down clamps are securely in place and not loose. Remove MTH and reinstall with engine at TDC, ensuring clamps are secure.
  - e. Inspect prop governor (if installed) per manufacturer's instructions for leaks and serviceability.
  - f. If surging is occurring at low RPM range (900 to 1300 RPM), first perform ignition check at engine manufacturer's recommended RPM setting for ignition checks. Follow steps in Condition #1 if RPM drops are out of specification. If RPM drops are normal for recommended engine run-up RPM, inspect fuel system for correct set-up. (In carbureted engines, surging in the low RPM band suggests the fuel system is set too lean; enrichen slightly per carburetor manufacturer instructions and see if problem improves).
  - g. If problem persists, contact the factory.
8. **Condition #6 – Engine will not start on EIS alone or is hard to start.** The engine not starting on the EIS alone can be caused by a number of problems. We will highlight the different inspections needed to resolve this problem.
- a. During the start sequence, what is RPM of the engine? The EIS needs a minimum of 60 RPM before it will begin to fire.
    - i. Examine the starter for proper operation.
    - ii. Examine the starter adapter (Continental) for proper operation.
    - iii. Examine the starter solenoid for proper operation.
    - iv. Correct any problems found.
  - b. Measure voltage drop during start sequence. The Electroair system requires a minimum of 8V based on bench testing, however, because of aging aircraft electrical systems, actual low voltage measured instantaneously may be lower. Check for weak battery. Correct aircraft electrical system as required.
  - c. Verify that the MTH is installed correctly. Follow steps in Condition #1, v & vi. Correct installation as necessary.
  - d. Check for bad/worn/small gauge starter cables. Correct as necessary.
  - e. Verify fuel system is working correctly.
  - f. If problem persists, contact the factory.

## **Chapter 8**

### **Section 08-00-00: Weight and Balance Information**

**General:** The installation of the EIS-41000 requires the removal of at least one Magneto and the installation of the EIS-41000 components. If two EIS-41000s are installed, then both magnetos will be removed. This installation results in a change to the aircraft's weight and balance. A new weight and balance should be calculated for the aircraft after the installation of the EIS-41000(s). All future loading calculations should use the updated aircraft weight and balance. The individual Electroair part weights are below. NOTE: For the twin-engine aircraft, the weight and balance must include the weight of both sets of EIS-41000 components.

Information below is provided as reference information only for engine installed components. There is no significant change with weight or center of gravity, however Electroair strongly recommends that a complete weight and balance check of the aircraft be performed when an engine is altered under this STC.

#### **Single MTH Kit**

1. EA-3000 or EA-24000: 1.5 pounds (Mag Timing Housing)
2. EA-4000: 1.1 pounds (Spark Plug Wires)

#### **Single CSTW Kit**

1. EA-4000: 1.1 pounds (Spark Plug Wires)
2. EA-9000A: 0.4 pounds (CSTW)

## **Chapter 20**

### **Section 20-00-00: Standard Practices – Engine**

**General:** These are the accepted Instructions for Continued Airworthiness for the modification performed in accordance with the Electroair EIS-41000 Series Electronic Ignition System Engine STC# SE04577CH. All references to the EIS-41000 in this document will refer to the Electroair EIS-41000 Electronic Ignition System Series Kits (EIS-41000(T)(LH)(IC)) and related components as specified in these Instructions for Continued Airworthiness (ICA). Performance of this ICA does not require any special training or practices outside of the Standard Practices and Methods outline in FAA AC43.13-1B, Acceptable Methods, Techniques and Practices. All tasks outlined here should be performed by a person or persons properly certificated by the FAA, or equivalent issued document under the appropriate governing Airworthiness Agency. Subsequent accepted changes to the ICA will be available to owners and operator of the STC through [www.electroair.net](http://www.electroair.net).

# Chapter 72 (R)

## Section 72(R)-00-00: General

Engine components operational check, when removed from airframe, can only be completed when interfaced with the following Electroair components.

1. EA-20000
2. EA-2000
3. EA-22000

And connected using the following wire diagram:

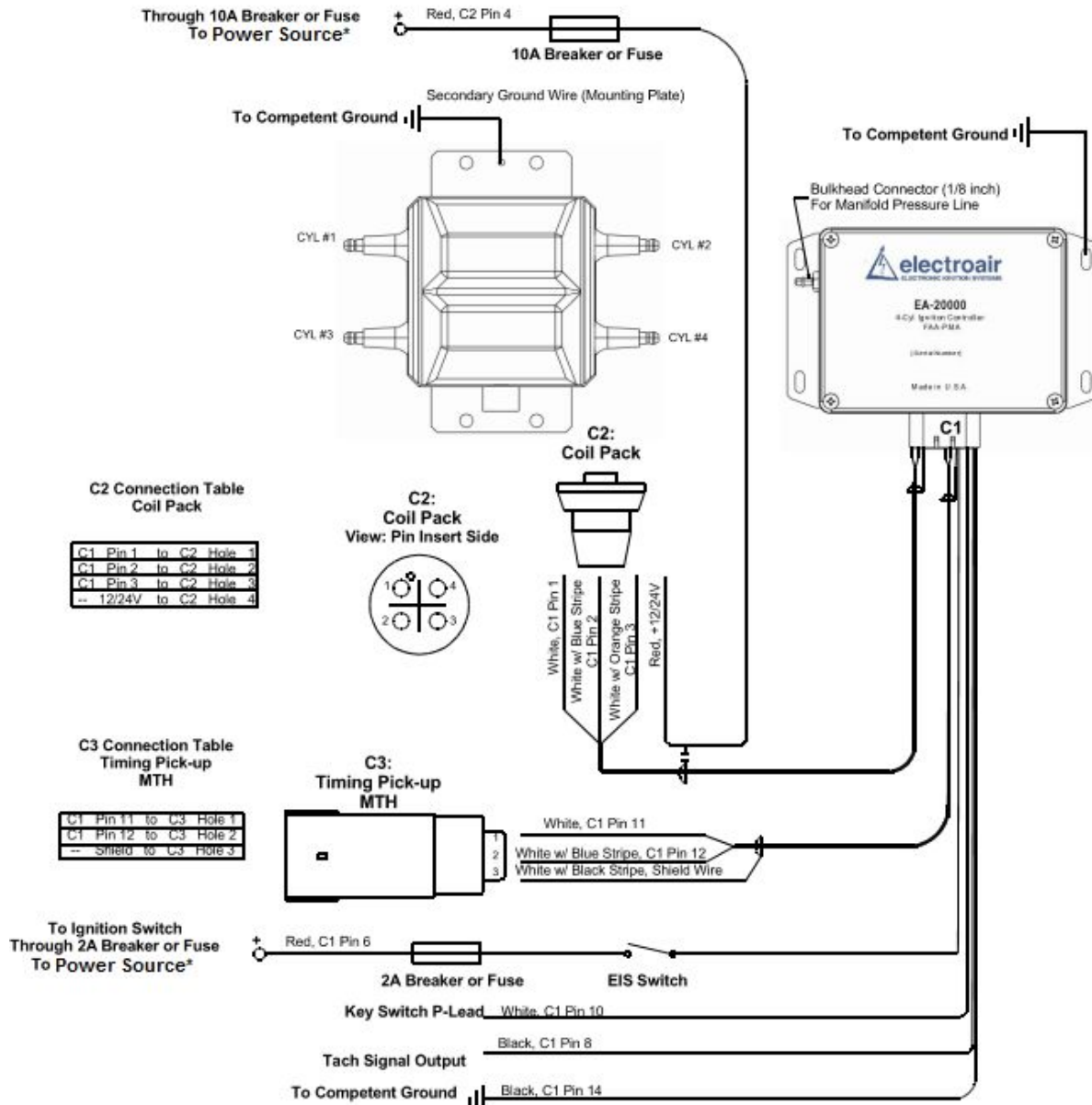


Figure 2: Wiring Diagram for EIS-41000, EIS-41000IC, EIS-41000LH, EIS-41000LHIC, EIS-41000T, EIS-41000TIC, EIS-41000TLH, & EIS-41000TLHIC

# Chapter 98

## Section 98-00-00: Wiring Diagrams for EIS-41000 Series Kits (Reference Only)

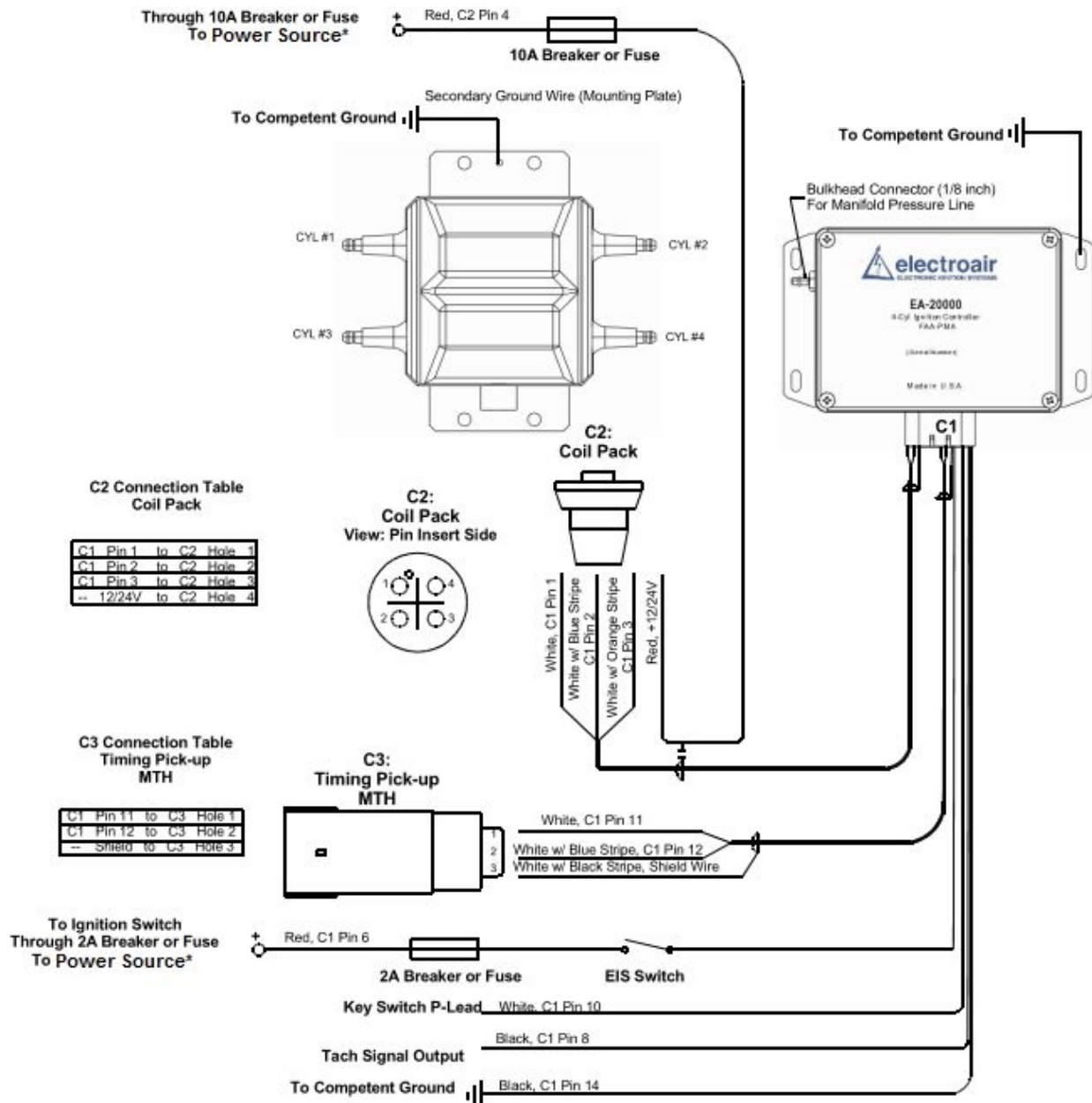


Figure 3: Wiring Diagram for EIS-41000, EIS-41000IC, EIS-41000LH, EIS-41000LHIC, EIS-41000T, EIS-41000TIC, EIS-41000TLH, & EIS-41000TLHIC

\* Power Source: See Figures 4-8.

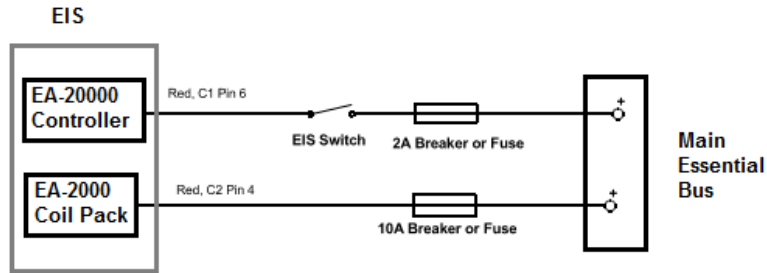


Figure 4: Single Engine, Single EIS Power Connection

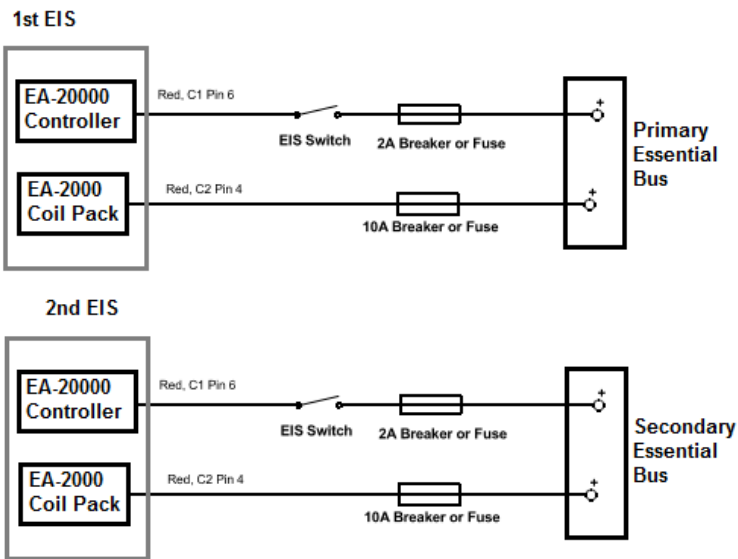


Figure 5: Single Engine, Dual EIS Electrical Power Connections

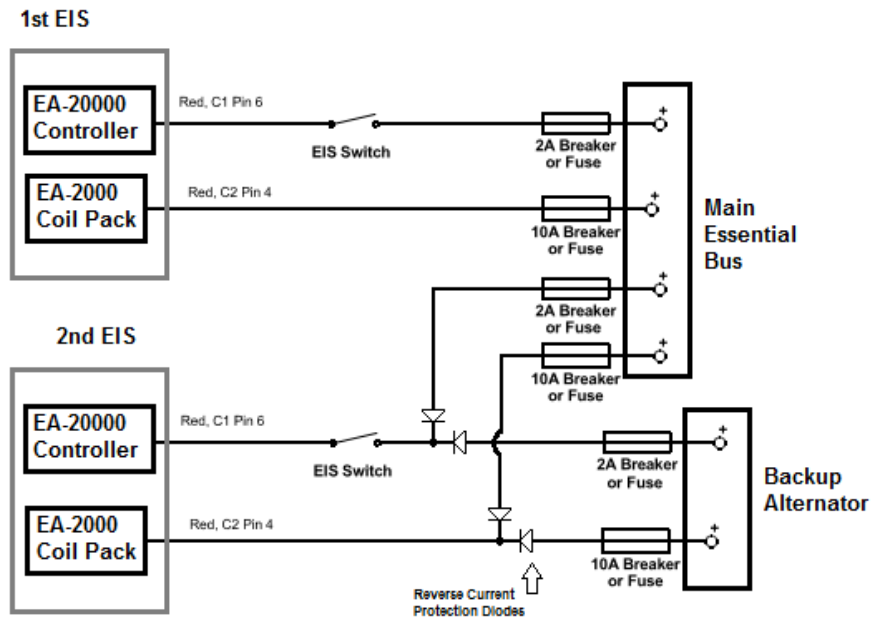


Figure 6: Single Engine, Dual EIS Backup Alternator Connections

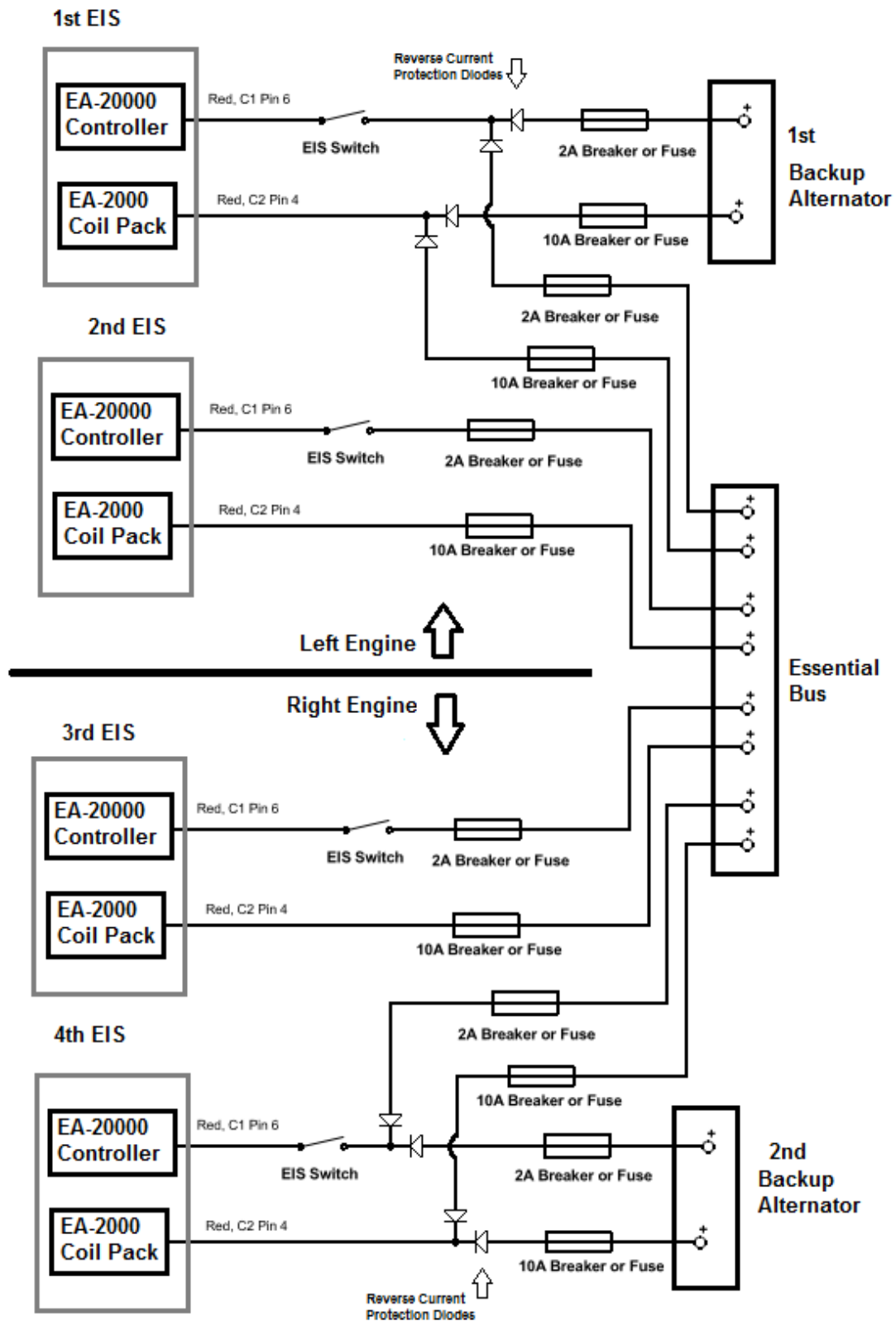
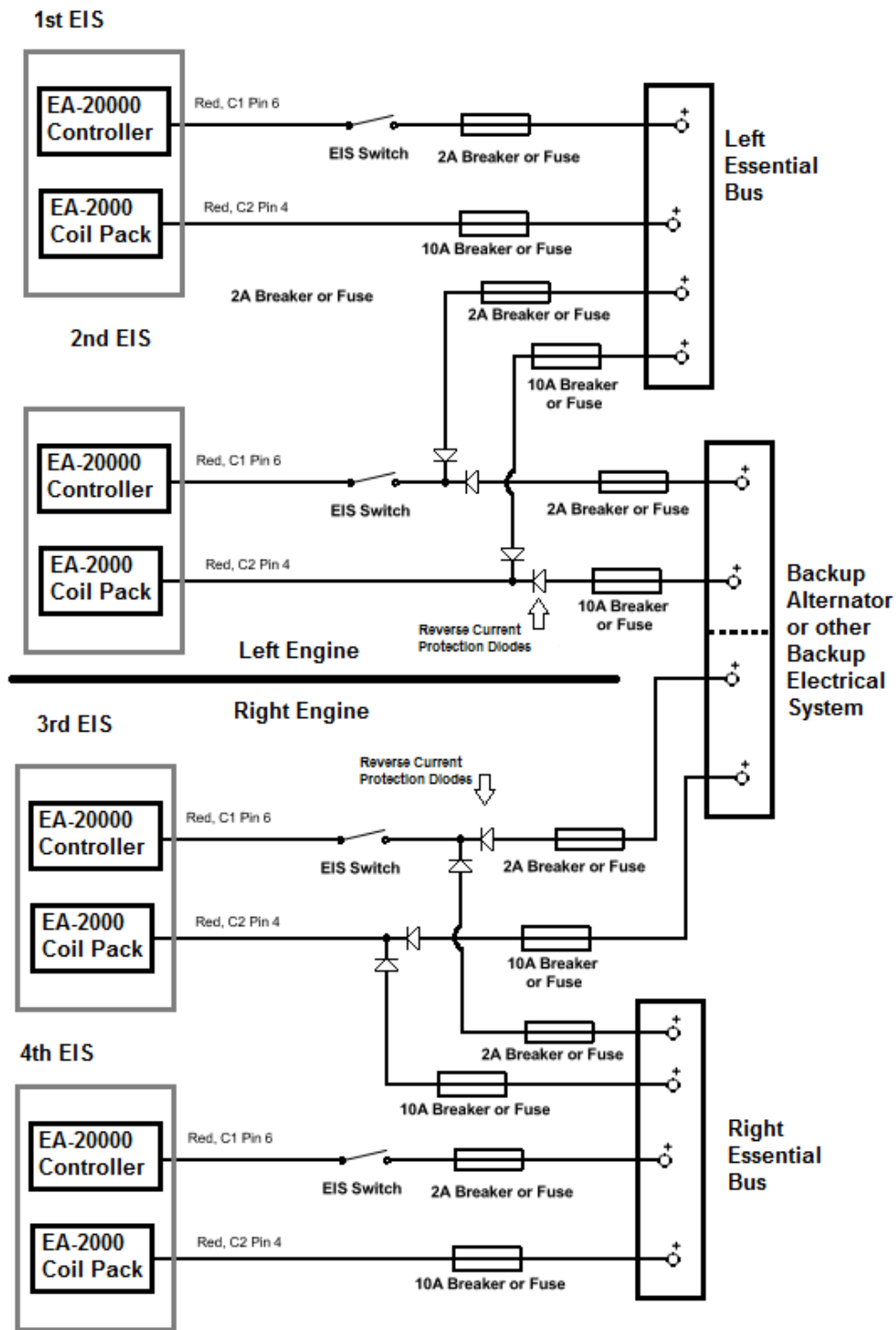


Figure 7: Twin Engine, Dual EIS, Single Electrical System Power Connections





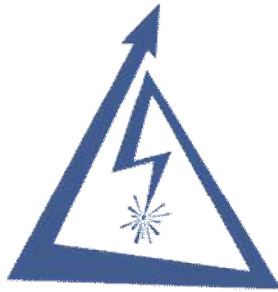
**Figure 8: Twin Engine, Dual EIS, Single Electrical System Power Connections**

- Backup power source may be shared or separate if they are independent of either engine's primary power source. See Section 49-00-00.

# ***Appendix A – Installation Manual***

Revision 00

Appendix A Rev00: IM EIS-41000 Revision 16 dated 12/14/2022



**electroair**  
ELECTRONIC IGNITION SYSTEMS

***EIS-41000***  
***Installation Manual***

***Electroair***  
***5097 Williams Lake Road***  
***Waterford, MI 48329 U.S.A.***  
***Ph: 248-674-3433 Fax: 248-64-4231***  
***Email: sales@electroair.net***

## **Table of Contents:**

Ignition System Technical Discussion .....	5
Ignition System Basics.....	5
Dual Magneto System Review.....	5
EIS Overview & Primer .....	5
How the Electroair EIS Works.....	6
High Resolution Crankshaft Position Sensor.....	7
Electrical Environmental Limitations.....	7
Applicable STCs .....	7
DUAL ELECTRONIC IGNITION SYSTEMS LIMITATIONS AND REQUIREMENTS.....	8
Spark Plug Discussion .....	10
EIS-41000 Kit Descriptions & Requirements .....	11
EIS-41000 System Description & Requirements:.....	11
EIS-41000IC System Description & Requirements: .....	11
EIS-41000T System Description & Requirements:.....	11
EIS-41000TLH System Description & Requirements: .....	11
EIS-41000TIC System Description & Requirements: .....	12
EIS-41000TLHIC System Description & Requirements:.....	12
Other items needed: .....	12
EIS-41000 Kit Contents & Optional Parts .....	13
EIS-41000 Kit Contents: .....	13
EIS-41000IC Kit Contents:.....	13
EIS-41000T Kit Contents: .....	13
EIS-41000TLH Kit Contents:.....	13
EIS-41000TIC Kit Contents:.....	13
EIS-41000TLHIC Kit Contents: .....	14
Receiving and Acceptance Checking of EIS Kit .....	15
Overview of Four Cylinder Single Engine Aircraft EIS Installation .....	16
Installation of EIS-41000 & EIS-41000IC.....	17
1. General Overview and Recommendations: .....	17
2. Removal of Old Ignition Components:.....	18
3. Set-up & Installation of p/n: EA-3000 MTH (For EIS-41000 Kit Only): .....	19
4. Set-up & Installation of p/n: EA-3000IC Impulse Coupled MTH (For EIS-41000IC Kit Only):	20
5. Set-up & Installation of p/n: EA-24000(LH) MTH .....	23
6. Set-up & Installation of p/n: EA-9000A CSTW kit: .....	25
7. Installation of p/n: EA-20000 EIS Controller and p/n: EA-2000 Coil Pack: .....	28
8. Connection of Manifold Pressure Line:.....	31
9. Installation of p/n: EA-4000 Spark Plug Harness:.....	32
10. Connection of p/n: EA-22000 Wiring Harness: .....	35
11. Final Installation Steps:.....	43
12. Installation Options available from Electroair:.....	44
Overview of Four Cylinder Twin Engine Aircraft EIS Installation.....	45
<i>Installation of EIS-41000T, EIS-41000TIC, EIS-41000TLH &amp; EIS-41000TLHIC .....</i>	<i>47</i>
1. General Overview and Recommendations: .....	47
2. Removal of Old Ignition Components:.....	48
3. Set-up & Installation of p/n: EA-3000 MTH (EIS-41000T Kit Only) and EA-3000LH MTH (EIS-41000TLH Kit Only): .....	49
4. Set-up & Installation of p/n: EA-3000IC MTH (EIS-41000TIC Kit Only) and EA-3000LHIC MTH (EIS-41000TLHIC Kit Only): .....	51

5.	Set-up & Installation of p/n: EA-24000(LH) MTH .....	54
6.	Set-up & Installation of p/n: EA-9000A CSTW kit: .....	56
7.	Installation of p/n: EA-20000 EIS Controllers and p/n: EA-2000 Coil Packs:.....	59
8.	Connection of Manifold Pressure Lines: .....	62
9.	Installation of p/n: EA-4000 Spark Plug Harnesses: .....	64
10.	Connection of p/n: EA-22000T Twin Engine Wiring Harnesses:.....	67
11.	Final Installation Steps: .....	76
12.	Installation Options Available from Electroair: .....	77
	Miscellaneous Information:.....	78
	Glossary and Abbreviations: .....	78
	Revision Log: .....	79

### **Table of Figures:**

Figure 1:	Vacuum Advance Curve.....	6
Figure 2:	Installation of MTH Alignment Pin .....	19
Figure 3:	Impulse Coupled MTH Shaft with Woodruff Keys Inserted. Step 4b .....	20
Figure 4:	Impulse Coupler and Faux Impulse Coupler Installed. Step 4c.....	21
Figure 5:	Drive Gear installed on MTH. Step 4d .....	21
Figure 6:	Install Order of Components to Impulse Coupled Shaft.....	22
Figure 7:	Installation of MTH Alignment Pin .....	23
Figure 8:	MTH Installation into magneto drive gear/cushions .....	24
Figure 9:	Typical installation of CSTW on a Lycoming 540 engine .....	25
Figure 10:	Components that make up the Lycoming CSTW Sensor Bracket.....	25
Figure 11:	Crank Shaft Trigger Wheel Positioning.....	27
Figure 12:	Correct Sensor Alignment .....	27
Figure 13:	P/N EA-20000 Overall and Hole Dimensions.....	28
Figure 14:	P/N EA-2000 Dimensions.....	29
Figure 15:	Spark Plug Wire Hardware Assembly.....	33
Figure 16:	C1 Connector.....	36
Figure 17:	MTH and 3 Pin Female Connector .....	36
Figure 18:	Coil Pack Harness Plug (C2).....	39
Figure 19:	Wiring Diagram for EIS-41000 & EIS-41000IC .....	41
Figure 20:	Single Engine, Single EIS Power Connection.....	42
Figure 21:	Single Engine, Dual EIS Dual Electrical System Power Connections .....	42
Figure 22:	Single Engine, Dual EIS Backup Alternator Connections .....	42
Figure 23:	Installation of MTH Alignment Pin on an EA-3000 MTH .....	49
Figure 24:	Impulse Coupled MTH Shaft with Woodruff Keys inserted. Step 4b .....	51
Figure 25:	Impulse Coupler and Faux Impulse Coupler Installed. Step 4c.....	52
Figure 26:	Drive Gear installed on MTH. Step 4d .....	52
Figure 27:	Install Order of Components to Impulse Coupled Shaft.....	53
Figure 28:	Installation of MTH Alignment Pin.....	54
Figure 29:	MTH Installation into magneto drive gear/cushions .....	55
Figure 30:	Typical installation of CSTW on a Lycoming 540 engine .....	56
Figure 31:	Components that make up the Lycoming CSTW Sensor Bracket.....	56
Figure 32:	Crank Shaft Trigger Wheel Positioning.....	58
Figure 33:	Correct Sensor Alignment .....	58
Figure 34:	P/N EA-20000 Overall and Hole Dimensions.....	59
Figure 35:	P/N EA-2000 Dimensions.....	60
Figure 36:	Spark Plug Wire Hardware Assembly.....	66
Figure 37:	C1 Connector.....	68

Figure 38: MTH and 3 Pin Female Connector .....69  
Figure 39: Coil Pack Plug Harness.....71  
Figure 40: Wiring Diagram for EIS-41000T, EIS-41000TIC, EIS-41000TLH, & EIS-41000TLHIC  
.....73  
Figure 41: Twin Engine, Dual EIS, Single Electrical System Power Connections .....74  
Figure 42: Twin Engine, Dual EIS, Dual Electrical System Power Connections.....75

# Ignition System Technical Discussion

## Ignition System Basics

The goal of any ignition system in a four-stroke engine is to start the combustion event so that peak pressure, as a result of combustion, occurs between 10 & 17 degrees after top dead center (ATDC) of the piston travel. This is the generally accepted range and the starting point when talking about ignition systems. From here we work backwards to understand how ignition systems work and what improvements can be made in order to get the most out of the engine.

## Dual Magneto System Review

Traditional aircraft engines use a dual, or two, Magneto Ignition System (MIS). Both magnetos are timed to fire at a preset degree before Top Dead Center (TDC). The two magneto system can be made up of a number of combinations: one impulse coupled magneto and one direct drive magneto; two impulse coupled magnetos; or two magnetos that have some kind of “starting help” device like a shower of sparks or “Slick-Start” system. No matter the combination, the magnetos are responsible for supplying energy to the spark plugs causing a “spark” which is used to ignite a fuel/air mixture inside of the cylinder. For decades, this kind of ignition system has been used quite successfully in aircraft engines. Traditional aircraft ignition systems, however, have remained stagnant in technological development and because of their inherent limitations, hand-cuff the engine’s ability to deliver peak performance.

Magnetos have two big limitations: one, they produce a relatively small amount of energy; and two, they can only provide that energy (or spark) at a fixed time point in the crank-shaft rotation. Magnetos typically can provide 12,000V through about 5 degrees of crank rotation at the spark plug – less during the start sequence (6,000-8,000 volts during starting). The fixed time point where the spark occurs means that the magneto cannot adjust the spark event to compensate for variances in fuel/air mixtures. As fuel/air mixtures varies (either because of altitude, air density, fuel density, etc.), the time required to develop peak pressure from combustion also changes. If the ignition event timing doesn’t change, then the time where peak pressure occurs MUST change. When this happens, the experience is typically a loss of power.

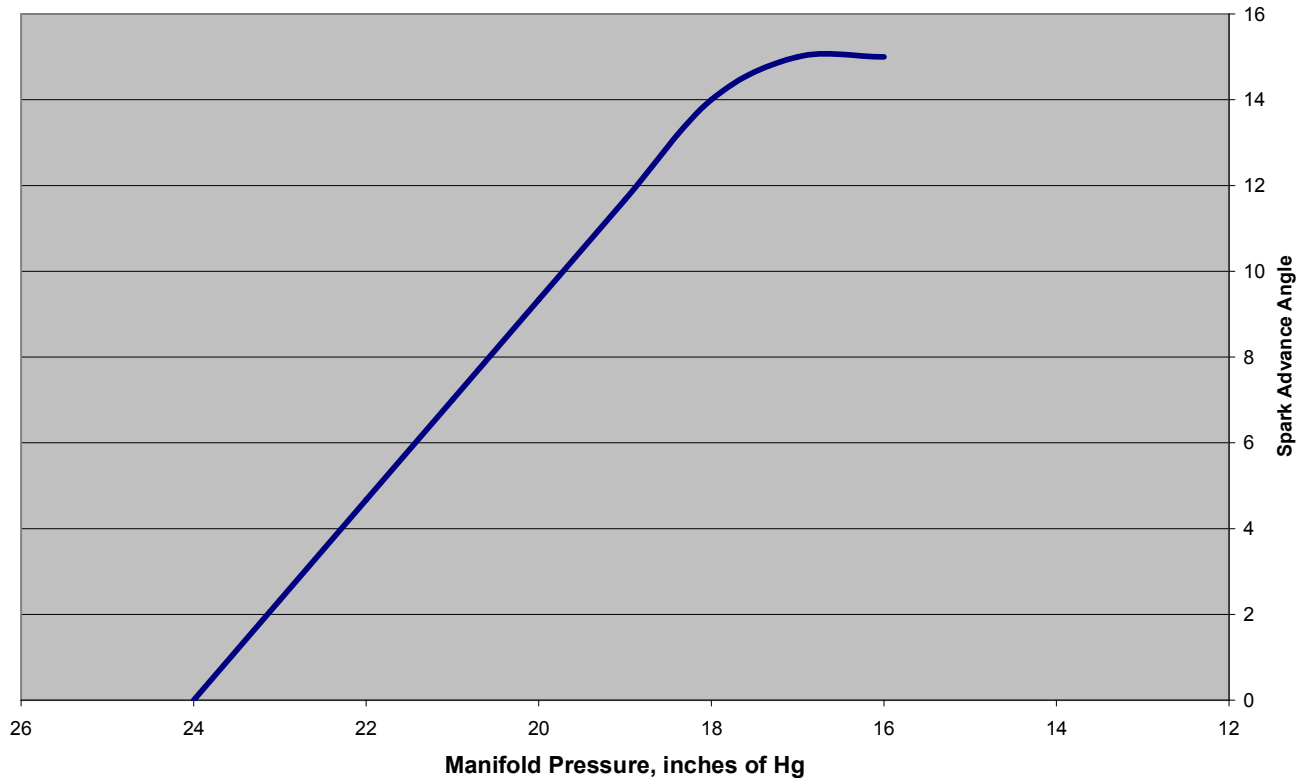
## EIS Overview & Primer

There are two principle differences between a magneto (MIS) and an electronic ignition system (EIS): one, an EIS is able to deliver much higher energy to the spark plug for a long period of time (70,000V through about 20 degrees of crank rotation) at any RPM; and two, an EIS is able to vary the ignition timing based on changes in the fuel/air mixture.

The very large voltage supplied to the spark plugs comes from using larger coils. The EIS’s ability to deliver that voltage at any RPM is because the output from the EIS is NOT dependent on engine RPM, but the battery supply. The high energy voltage from the EIS allows for a larger gap in the spark plug – insuring a big, long duration, high quality spark. This spark will then have the ability to ignite typically any kind of fuel/air mixture that passes by the spark plug. This is particularly important for hot-start applications, where the fuel/air mixture is corrupt in some way, caused by the high temperature, poor fuel quality, or any combination thereof.

The ability to vary spark timing is also critical. Any good propulsion engineer will pontificate that the way to develop power out of an engine is directly related to the amount of air that can be put into the combustion chamber (fuel can always be metered). Aircraft engines battle this problem

constantly with changing altitude and poorly designed intake systems. A good way of measuring the amount of air in the combustion chamber is by measuring Manifold Absolute Pressure (MAP). This directly correlates to the amount of air available for combustion. The EIS looks at MAP, and adjusts timing based on this to optimize the location (or degree of crank position) for the spark event to occur. The Electroair EIS uses the vacuum advance curve found in Figure 1 for adjusting timing based on MAP.



**Figure 1: Vacuum Advance Curve**

### **How the Electroair EIS Works**

The Electroair EIS fires the spark plugs directly from the coils, not through a distributor. This is accomplished by using multiple coils, each with two spark terminals. The coil terminals are connected to the spark plugs, allowing one cylinder to fire on compression while its companion cylinder fires simultaneously on exhaust. Open spark gaps in the rotor and cap are eliminated, making wear and moisture problems a thing of the past.

What sets the Electroair Electronic Ignition System apart from others is the ability to charge multiple ignition coils at the same time. This increased dwell time means that full spark energy is available over the entire RPM range (up to 9600 RPM at 12 or 24 volts). Unlike capacitive discharge systems that only put out one very short spark, the EIS puts out a full energy, long burning spark at the highest and most critical engine speeds. Long burn times assure effective burning of even rich fuel mixtures.

The EIS Controller includes software, which takes the electrical signal from the crankshaft (or mag timing housing) sensor, identifies top-dead center, and then keeps track of the remaining



rotation. The EIS determines engine speed and computes the spark advance using the settings pre-set at the factory for the engine as a baseline. Settings from the factory are preset for the engine's certified placarded timing. Additionally, the EIS receives engine manifold pressure information and advances the ignition to compensate for altitude and throttle position.

Beyond the synchronization and firing the plugs at the correct advance angle, the EIS also computes the exact dwell time to produce 6 amps of coil current. Coil charging is dynamically measured, so changes in RPM, battery voltage, or temperature are accounted for on every spark. This corrects any errors that are caused by battery voltage or coil temperature changes and insures maximum spark energy.

## High Resolution Crankshaft Position Sensor

The EIS uses a single, high resolution, 60-minus-2 tooth crankshaft position trigger wheel. The trigger wheel is either installed in a timing mechanism that is installed in a mag hole (aka Mag Timing Housing or MTH), or a trigger wheel is installed directly on the crankshaft just behind the prop flange. This affords resolution unheard of in any other electronic ignition available today, offering spark accuracy of  $\frac{1}{4}$  degree of crankshaft rotation. This accuracy means the system is ideal for the most demanding engine applications – *that's why the Electroair EIS has accomplished altitude and speed records in the industry.* The Crank Shaft Trigger Wheel (CSTW) can be used in situations where an MTH cannot be installed such as on engines that use single-drive dual magnetos, where only one mag hole is available. For Lycoming engines, if a mag hole is available, the CSTW can still be installed on the crankshaft along with a plate to cover the open mag hole.

In summary, the Electroair EIS delivers more power because:

- Spark timing is precisely controlled under all conditions, including rapid engine acceleration.
- Longer dwell time and better propagation allows the engine to run better on various mixture settings.
- Accurate spark timing allows sustained engine operation closer to desired peak power timing.
- 100% spark energy up to 9600 RPM on 6-cylinder applications (at 12 or 24 volts).
- Longer spark duration!
- Built-in timing program.
- No power draining magnetos to drive.
- No moving parts to wear out or adjust.

## Electrical Environmental Limitations

- Radiated Susceptibility – Tested to DO-160G section 20 category T
- Conducted Susceptibility– Tested to DO-160G section 20 category T
- Conducted Emissions – Tested to DO-160G section 21 category B
- Radiated Emissions – Tested to DO-160G section 21 category B
- Lightning – Tested to DO-160G section 22 category A3J3L3

## Applicable STCs

The following STCs are applicable for this document.

- SA02987CH
- SE04577CH

## DUAL ELECTRONIC IGNITION SYSTEMS LIMITATIONS AND REQUIREMENTS

The electrical power requirements for engines equipped with dual electronic ignition systems will require a separate source of backup electrical power that is independent of the primary source. The separate source of electrical power can take one to the following forms:

- **Backup Battery**: This system is the simplest installation for a single or twin engine aircraft certified with a single or dual batteries and alternator electrical system. For a dual EIS installation on single engine aircraft, only one EIS may be connected to the backup battery. For a dual EIS installation on a twin engine aircraft, one EIS from each engine may be connected to the same backup battery. The backup battery current rating must be greater than the current load of the two EIS. The other EIS on each engine must have separate and independent power sources. Alternatively, for a dual EIS installation on a twin engine aircraft one EIS on each engine may be connected to a separate and independent backup battery. There will be at least three independent power sources for the dual EIS on a twin: the backup battery and two others. No other devices or loads may be connected to the backup battery when it is used as a back-up battery for an EIS. Using a backup battery requires a method of determining the backup battery charge state in order to meet the minimum backup power requirements.
  - **Note**: A backup power source may include a rechargeable battery system that meets TSO-C173a / RTCA DO-293A for Lead acid and Ni-Cad batteries, TSO-C179b / RTCA DO-311A for Lithium batteries, or TSO C-142b / RTCA DO-227A for non-rechargeable lithium batteries. The system must include a state of charge indication available before each flight. A pre-flight indication of battery state of charge must be provided to the crew.
  - **Note**: A backup power source may utilize a non-rechargeable battery that meets TSO-C142b. The non-rechargeable battery must be replaced on a periodic basis that ensures sufficient capacity is available to meet the requirements below. Use of a non-rechargeable battery also requires an indication to the crew anytime power from the backup battery is used in which case mandatory replacement is required.
- **Dual Electrical System**: On aircraft with a dual battery or dual alternator/generator systems with independent primary electrical busses, power from each of the electrical busses can be used when the failure of one electrical system is isolated from the other system.
  - **Note**: Twin-engine applications with dual electrical systems may share a common backup power source, independent of either engine's primary power source, which can provide electrical power after loss of power from both independent electrical systems.
- **Backup Alternator/Generator System**: This system differs from the Dual Electrical System because the backup alternator/generator is not used as a primary source of aircraft electrical power. The backup alternator/generator is used, as an alternate source of electrical power should the primary system fail. These systems are usually attached to either a dedicated or an essential buss and offer reduced current capability when compared to the primary system.

The following must be shown for any backup power supply configuration proposed on any airplane engine installation equipped with a dual EIS.

- (1) If any emergency or other procedure recommends or requires the shutoff of any or all electrical systems in flight, such as for smoke in the cabin or loss of a power generation, then a dedicated backup power source must be provided, which is independent of the primary electrical system and automatically available when any electrical system is shutoff in flight. This applies to both single and dual buss systems on single and multi-engine airplanes.
- (2) For any one engine on a single or multi-engine airplane, it must take at least two independent power source failures for a LOPC event
- (3) For twin-engine airplanes, it must take at least three independent power source failures for a LOPC event in both engines.
- (4) For twin-engine installations, the design must continue to meet the powerplant isolation requirements of §23.903(c), including in at least one configuration, an independent power supply for at least one EIS on each engine.

The minimum requirements for the electrical power system are addressed in 14 CFR 23.1309, 23.1351, 23.1353, 23.1357, 23.1359, 23.1361, 23.1365 and 23.1367. The time required in 14 CFR 23.1353(h) is the minimum time for backup electrical power in the event of a failure of primary aircraft electrical power. The backup power does not need to be wholly dedicated to the electronic ignition system since other critical systems may be supplied by the backup electrical power. However, following the loss of the primary power generation system, a minimum of 60 minutes of backup electrical power for the electronic ignition system is highly recommended. Additionally, the inherent redundancy of an independent power source dedicated to the electronic ignition system is also highly recommended when considering an aircraft electrical power failure.

A four-cylinder dual electronic ignition system will consist of two separate Electroair EIS-41000 series kits installed on a single engine or four separate EIS-41000 series kits for dual-EIS on twin engine aircraft (two EISs per engine). For aircraft with a dual, or back-up alternator, one EIS shall be attached directly to the back-up alternator. The load attached to each alternator shall not exceed 80% of the total capacity for the alternator (AC43-13-1B, Chapter 11, Section 11-35), and may need to be adjusted to allow for supplying power to one of the Electroair Electronic Ignition Systems (when dual Electroair systems are installed).

## Spark Plug Discussion

The installation manual specifies the recommended gap for the engine application. This gap will be larger than a typical aircraft plug gap because of the higher energy output from the EIS. This is perfectly acceptable with the EIS ignition charging method, since the high load of the cylinder pressure will allow the voltage to be quite high at the electrode; the gap will keep the plug from seeing an over-voltage situation.

The EIS system uses an *inductive* long duration charging method for the coils. Electroair's experience has drawn us to the following guidelines for spark plug selection:

- Electroair manufactures aviation spark plugs that are gapped at the factory to Electroair's recommended wide gap of 0.036 inches. Electroair manufactures both massive electrode and fine wire spark plugs for various applications. The spark plug information can be found on the Electroair website ([www.electroair.net](http://www.electroair.net)). Electroair spark plugs have been FAA approved for use with Electroair's certified EIS-41000 and EIS-61000 ignition systems. These plugs are only approved for use with Electroair's EIS. Electroair spark plugs should not be used with magnetos.
- Select aircraft spark plugs that will work with the EIS. For Lycoming engines, Electroair has found that the REM37BY (or equivalent) plugs work the best because they are easier to gap to the range required and fit the broadest heat range recommended by the engine manufacturers. (Fine wire plugs are also an excellent choice for Lycoming engines). For Continental Engines requiring long reach spark plugs, off-the-shelf fine wire spark plugs will generally be the easiest to adjust the gap. Electroair strongly recommends verifying the heat range for the engine and using the appropriate plugs.

## **EIS-41000 Kit Descriptions & Requirements**

### **EIS-41000 System Description & Requirements:**

1. This EIS Kit replaces one NON-impulse coupled magneto on the engine of a single engine aircraft
2. 12V or 24V electrical system capable of 0.75A
3. Manifold pressure line for variable timing
4. A Direct Drive Magneto gear (NOT PROVIDED IN EIS KIT)
5. Toggle Switch x 1, capable of handling 12/24 volts and at least 0.75A (NOT PROVIDED IN EIS KIT)
6. 2 amp circuit breaker or fuse x 1 (NOT PROVIDED IN EIS KIT)
7. 10 amp circuit breaker or fuse x 1 (NOT PROVIDED IN EIS KIT)

### **EIS-41000IC System Description & Requirements:**

1. This EIS Kit replaces one impulse coupled magneto on the engine of a single engine aircraft
2. 12V or 24V electrical system capable of 0.75A
3. Manifold pressure line for variable timing
4. A Magneto Drive Gear (NOT PROVIDED IN EIS KIT)
5. Toggle Switch x 1, capable of handling 12/24 volts and at least 0.75A (NOT PROVIDED IN EIS KIT)
6. 2 amp circuit breaker or fuse x 1 (NOT PROVIDED IN EIS KIT)
7. 10 amp circuit breaker or fuse x 1 (NOT PROVIDED IN EIS KIT)

### **EIS-41000T System Description & Requirements:**

1. This EIS Kit replaces one NON-impulse coupled magneto on ONE standard-rotating engine of a twin engine aircraft
2. 12V or 24V electrical system capable of 0.75A
3. Manifold pressure line for variable timing
4. A Direct Drive Magneto gear (NOT PROVIDED IN EIS KIT)
5. Toggle Switch x 1, capable of handling 12/24 volts and at least 0.75A (NOT PROVIDED IN EIS KIT)
6. 2 amp circuit breaker or fuse x 1 (NOT PROVIDED IN EIS KIT)
7. 10 amp circuit breaker or fuse x 1 (NOT PROVIDED IN EIS KIT)

### **EIS-41000TLH System Description & Requirements:**

1. This EIS Kit replaces one NON-impulse coupled magneto on the counter-rotating engine of a twin engine aircraft
2. 12V or 24V electrical system capable of 0.75A
3. Manifold pressure line for variable timing
4. A Direct Drive Magneto gear (NOT PROVIDED IN EIS KIT)
5. Toggle Switch x 1, capable of handling 12/24 volts and at least 0.75A (NOT PROVIDED IN EIS KIT)
6. 2 amp circuit breaker or fuse x 1 (NOT PROVIDED IN EIS KIT)
7. 10 amp circuit breaker or fuse x 1 (NOT PROVIDED IN EIS KIT)

**EIS-41000TIC System Description & Requirements:**

1. This EIS Kit replaces one impulse coupled magneto on ONE standard-rotating engine of a twin engine aircraft
2. 12V or 24V electrical system capable of 0.75A
3. Manifold pressure line for variable timing
4. A Magneto Drive Gear (NOT PROVIDED IN EIS KIT)
5. Toggle Switch x 1, capable of handling 12/24 volts and at least 0.75A (NOT PROVIDED IN EIS KIT)
6. 2 amp circuit breaker or fuse x 1 (NOT PROVIDED IN EIS KIT)
7. 10 amp circuit breaker or fuse x 1 (NOT PROVIDED IN EIS KIT)

**EIS-41000TLHIC System Description & Requirements:**

1. This EIS Kit replaces one impulse coupled magneto on the counter-rotating engine of a twin engine aircraft
2. 12V or 24V electrical system capable of 0.75A
3. Manifold pressure line for variable timing
4. A Magneto Drive Gear (NOT PROVIDED IN EIS KIT)
5. Toggle Switch x 1, capable of handling 12/24 volts and at least 0.75A (NOT PROVIDED IN EIS KIT)
6. 2 amp circuit breaker or fuse x 1 (NOT PROVIDED IN EIS KIT)
7. 10 amp circuit breaker or fuse x 1 (NOT PROVIDED IN EIS KIT)

**Other items needed:**

1. If replacing a Bendix Magneto, the Slick-type MAG holders are needed to mount the EA-3000, EA-3000IC, EA-3000LH, EA-3000LHIC, EA-24000, or EA-24000LH.
2. Basic tools and standard aircraft hardware required for mounting EIS controller and coil pack.
3. Electrical tools for cutting, stripping and terminating various wiring. Also recommended is a good selection of cable ties for harness routing and tie-off.
4. If replacing the impulse coupled magneto on a Continental Engine, the impulse coupler and drive gear will be needed.

## **EIS-41000 Kit Contents & Optional Parts**

### **EIS-41000 Kit Contents:**

1. \_\_\_ EIS Controller (EA-20000) with secondary ground wire
2. \_\_\_ Coil Pack (EA-2000) with mounting plate and hardware kit
3. \_\_\_ MAG Timing Housing (EA-3000) or Crankshaft Trigger Wheel (EA-9000A) with hardware kit
4. \_\_\_ Spark Plug Wires (EA-4000) x2 Bundles, (2) bundles make (4) leads
5. \_\_\_ EA-4000 REM Hardware Kit
6. \_\_\_ Wiring Harness (EA-22000)
7. \_\_\_ USB Drive Containing System Documents (Installation Manual)

### **EIS-41000IC Kit Contents:**

1. \_\_\_ EIS Controller (EA-20000) with secondary ground wire
2. \_\_\_ Coil Pack (EA-2000) with mounting plate and hardware kit
3. \_\_\_ MAG Timing Housing (EA-3000IC or EA-24000) with hardware kit
4. \_\_\_ Spark Plug Wires (EA-4000) x2 Bundles, (2) bundles make (4) leads
5. \_\_\_ EA-4000 REM Hardware Kit
6. \_\_\_ Wiring Harness (EA-22000)
7. \_\_\_ USB Drive Containing System Documents (Installation Manual)

### **EIS-41000T Kit Contents:**

1. \_\_\_ EIS Controller (EA-20000) with secondary ground wire
2. \_\_\_ Coil Pack (EA-2000) with mounting plate and hardware kit
3. \_\_\_ MAG Timing Housing (EA-3000) or Crankshaft Trigger Wheel (EA-9000A) with hardware kit
4. \_\_\_ Spark Plug Wires (EA-4000T) x2 Bundles, (2) bundles make (4) leads
5. \_\_\_ EA-4000 REM Hardware Kit
6. \_\_\_ Twin Engine Wiring Harness (EA-22000T)
7. \_\_\_ Instrument Panel Label Kit
8. \_\_\_ USB Drive Containing System Documents (Installation Manual)

### **EIS-41000TLH Kit Contents:**

1. \_\_\_ EIS Controller (EA-20000) with secondary ground wire
2. \_\_\_ Coil Pack (EA-2000) with mounting plate and hardware kit
3. \_\_\_ MAG Timing Housing (EA-3000LH) or Crankshaft Trigger Wheel (EA-9000A) with hardware kit
4. \_\_\_ Spark Plug Wires (EA-4000T) x2 Bundles, (2) bundles make (4) leads
5. \_\_\_ EA-4000 REM Hardware Kit
6. \_\_\_ Twin Engine Wiring Harness (EA-22000T)
7. \_\_\_ Instrument Panel Label Kit
8. \_\_\_ USB Drive Containing System Documents (Installation Manual)

### **EIS-41000TIC Kit Contents:**

1. \_\_\_ EIS Controller (EA-20000) with secondary ground wire
2. \_\_\_ Coil Pack (EA-2000) with mounting plate and hardware kit

3. \_\_\_ MAG Timing Housing (EA-3000IC or EA-24000) with hardware kit
4. \_\_\_ Spark Plug Wires (EA-4000T) x2 Bundles, (2) bundles make (4) leads
5. \_\_\_ EA-4000 REM Hardware Kit
6. \_\_\_ Twin Engine Wiring Harness (EA-22000T)
7. \_\_\_ Instrument Panel Label Kit
8. \_\_\_ USB Drive Containing System Documents (Installation Manual)

**EIS-41000TLHIC Kit Contents:**

1. \_\_\_ EIS Controller (EA-20000) with secondary ground wire
2. \_\_\_ Coil Pack (EA-2000) with mounting plate and hardware kit
3. \_\_\_ MAG Timing Housing (EA-3000LHIC or EA-24000LH) with hardware kit
4. \_\_\_ Spark Plug Wires (EA-4000T) x2 Bundles, (2) bundles make (4) leads
5. \_\_\_ EA-4000 REM Hardware Kit
6. \_\_\_ Twin Engine Wiring Harness (EA-22000T)
7. \_\_\_ Instrument Panel Label Kit
8. \_\_\_ USB Drive Containing System Documents (Installation Manual)



## Receiving and Acceptance Checking of EIS Kit

1. Review the packaging before acceptance from the freight carrier. If damaged, refuse the package.
2. Open the package. Components of the EIS kit are inserted into different sections and each component should be handled with care.
3. Review the contents of the package to the content listing on the package.
4. Are all of the materials there?
  - a. Yes, proceed to step 5.
  - b. No, contact the factory. Have the serial number of the kit available when contacting. (factory 248-674-3433 or [sales@electroair.net](mailto:sales@electroair.net))
5. Inspect the controller for damage to the aluminum housing. Verify that the placarded controller timing matched the placarded engine timing. If not contact Electroair 248-674-3433 or [sales@electroair.net](mailto:sales@electroair.net).
6. Inspect the wires for nicks and cracks.
7. Inspect the coil pack and plate for external damage.
8. Inspect the CSTW/MTH for external damage.
9. Are all materials acceptable?
  - a. Yes, proceed with installation.
  - b. No, contact the factory. Have the serial number of the kit available when contacting. (factory 248-674-3433 or [sales@electroair.net](mailto:sales@electroair.net))

If possible, store parts in original packaging when not in use. If not possible, wrap parts in cushioning material and place in one location. Review above prior to reinstallation.

For latest copies of documentation, refer to [www.electroair.net](http://www.electroair.net).

- AML
- AFMS
- ICA
- Installation Manual
- STC

# Overview of Four Cylinder Single Engine Aircraft EIS Installation

Thank you for purchasing an Electroair Ignition System. Electroair is confident in that you will be happy with the performance of this EIS on the aircraft. The next several pages are a step-by-step process of installing the EIS on the aircraft. Electroair hopes the experience will be enjoyable and that this manual will provide clear direction and guidance through this process. This manual will cover the following general installation steps:

1. General overview and recommendations
2. Removal of old ignition components
3. Set-up & Installation of p/n: EA-3000 MTH (EIS-41000 Kit Only)
4. Set-up & Installation of p/n: EA-3000IC Impulse Coupled MTH (EIS-41000IC Kit Only)
5. Set-up & Installation of p/n: EA-24000(LH) MTH
6. Set-up & Installation of p/n: EA-9000A CSTW Kit
7. Installation of p/n: EA-20000 EIS Controller and p/n: EA-2000 Coil Pack
8. Connection of Manifold Pressure Line
9. Installation of p/n: EA-4000 Spark Plug Harness
10. Connection of p/n: EA-22000(T) Wiring Harness
11. Final installation steps
12. Installation Options available from Electroair

Electroair strongly recommends reading through this entire installation procedure before installing the EIS on the aircraft. Make sure that any questions are answered before the actual installation. Also, make sure any extra components needed, e.g. cable ties, circuit breakers, switch terminations, etc., are all available. Removal of old components and installation of new components is to be completed in compliance with CFR Title 14 Part 43, as applicable, and any Airframe or Engine Manufacturer Maintenance Procedures, as applicable. Above all else, use good common sense and professional judgment. An electronic ignition system is a high voltage device. If an EIS is improperly installed, maintained, or misfired, severe damage to the EIS, the aircraft, the engine, or the installer may result.

Please contact Electroair (248-674-3433 or [sales@electroair.net](mailto:sales@electroair.net)) with any questions during this installation process. Good luck and happy flying!!

Electroair

## Installation of EIS-41000 & EIS-41000IC

### **1. General Overview and Recommendations:**

- a. Read through the entire installation instructions before beginning the installation to make sure each step is understood. Contact Electroair (248-674-3433 or [sales@electroair.net](mailto:sales@electroair.net)) if there are any questions or if any items that are unclear.



## **VERIFY TIMING CONTROLLER PLACARD TO ENGINE PLACARD**

- b. If controller placarded timing does not match engine placarded timing, contact Electroair (248-674-3433 or [sales@electroair.net](mailto:sales@electroair.net)). The controller will need to be re-timed before installation.
- c. This ignition system is designed to be installed by aviation professionals with the appropriate ratings and experience for maintaining General Aviation aircraft.
- d. If pre-existing components on the airframe are in the way of or are in close proximity to the installation locations of the EIS components, Electroair Acquisition Corp. recommends that following the procedures listed below.  
**NOTE:** When making ANY changes or modifications to the aircraft or aircraft components, make sure all practices are in accordance with CFR Title 14 Part 43.
  - i. If the preexisting components can be relocated, move the components to an acceptable location on the airframe where they will not come into contact with the EIS component(s).
  - ii. If the preexisting components must come into contact or close proximity to the EIS component(s), make sure to protect all components from each other. This could mean, but not limited to, adding anti-chafing material, additional component securing devices, heat shielding material, etc.
- e. Always use good safety and work practices. Use appropriate safety equipment (safety glasses, etc.) and precautions. The EIS is a high voltage system and if installed or tested incorrectly can cause substantial damage to both the system and the installer.

## **2. Removal of Old Ignition Components:**

- a. Any removed articles that will be re-used (gears, impulse couplings) should be inspected for condition before re-installation.
- b. Remove cowling. Verify that Master Switch is off and battery is disconnected.
- c. **IMPORTANT:** Determine which magneto will be replaced, either the right or the left magneto and whether it is direct drive or impulse coupled magneto. **Note:** If an impulse coupled magneto is being replaced; EIS-41000IC kit is needed.
  - i. When replacing a direct drive type magneto, the magneto will have single gear installed on its drive shaft. This gear will be reused to install p/n: EA-3000 MAG Timing Housing.
  - ii. When replacing an impulse coupled magneto, the magneto will have an impulse coupler installed on its drive shaft and a drive gear installed on top of the impulse coupler. The drive gear will be reused to install p/n: EA-3000IC Impulse Coupled MAG Timing Housing. **NOTE:** The impulse coupler will be needed for Continental engines. The impulse coupler will be used for its dimensions only, and not its functionality for retarding the spark on start-up. For Lycoming engines, a faux impulse coupler will be provided in the EA-3000IC hardware kit.
- d. Remove ignition harness from the spark plugs associated with the magneto that is being replaced.
- e. Disconnect the P-lead that is installed on the magneto that is being replaced from the ignition switch.
- f. Remove the selected magneto, the selected magneto's ignition harness, and selected magneto's P-lead from ignition switch. Retain the magneto hold down clips; they will be used to install the MTH (either p/n: EA-3000, EA-3000IC, or EA-24000).
- g. Remove the magneto drive components, as detailed in step 2b, from the magneto. Be careful not to damage the drive components. Electroair recommends using a standard gear puller. Retain drive components for installation of either p/n: EA-3000 or p/n: EA-3000IC.
- h. Remove spark plugs if new plugs are going to be used (recommended) with the electronic ignition system.
- i. For Dual EIS Installations, repeat steps a-g to replace the other magneto.
- j. For single-drive dual magneto replacement, please prepare the dual-magneto core for return to Electroair. With the core return, also include copies of the engine logbook showing when dual mag was installed and removed. Call Electroair if there are any questions.

### **3. Set-up & Installation of p/n: EA-3000 MTH (For EIS-41000 Kit Only):**

- a. Retrieve p/n: EA-3000 MTH and the EA-3000 MTH Hardware Kit.
- b. Insert the woodruff key into the key slot on the MTH shaft.
- c. Place the direct drive magneto gear on the MTH shaft. Be sure to align the Woodruff (half-moon shape) key with the slot in the gear.
- d. Install the washer and nut onto the MTH shaft and tighten the nut to the same torque value as recommended by the magneto manufacturer (Bendix or Slick). Install the cotter pin through the castle nut and MTH shaft with the long end of the cotter pin facing away from the MTH. Bend the long end of the cotter pin over the end of the shaft and the short end along the side of the nut. The direct drive gear is now installed onto the MTH shaft.
- e. Holding the MTH, insert the alignment pin in the alignment hole on the back cover (pin supplied with hardware kit). Slowly turn the gear on the front of the unit until the alignment pin drops into a second hole inside the MTH. The MTH is now set to Top Dead Center (TDC) and the MTH shaft should not be able to spin. Leave the alignment pin in the MTH and ready the engine for the MTH installation (next steps). See Figure 2 for an example.



Figure 2: Installation of MTH Alignment Pin

- f. Clean magneto pad on the engine. Install new gasket on p/n: EA-3000.
- g. **VERIFY MASTER SWITCH IS OFF AND BATTERY IS DISCONNECTED.**
- h. Rotate the engine to Top Dead Center (TDC) for cylinder # 1. This done by rotating the prop ***in the direction of the engine rotation*** until TDC is reached. Verify TDC using the timing marks found on the engine. **NOTE:** Consult engine manufacturer ICA for identifying number 1 cylinder and timing marks. Typically, the first set is on the fly wheel and the starter; they will line up at TDC; the second set may be another mark on the backside of fly wheel which lines up with the engine case seam at TDC. If any of these indications are not correct, repeat this step until they are. Other safe methods for obtaining TDC may be used, such as observing the cylinder movement through the spark plug holes. ***Always rotate the engine in the direction that it rotates during operation.***
- i. Install the MTH into the proper magneto hole. Secure the MTH using the mag holding clips referenced in step 2e and secure per engine manufacturer specifications.

- j. **REMOVE THE ALIGNMENT PIN.** Failure to remove the MTH Alignment Pin may cause damage to the MTH, the engine, or both.
- k. P/N EA-3000 is now installed and timed properly.
- l. If installing a 2<sup>nd</sup> EIS-41000 for dual EIS, repeat steps 3a-3k for 2<sup>nd</sup> EA-3000.

**4. Set-up & Installation of p/n: EA-3000IC Impulse Coupled MTH (For EIS-41000IC Kit Only):**

- a. Retrieve p/n: EA-3000IC Impulse Coupled MTH and the EA-3000IC Impulse Coupled MTH Hardware Kit.
- b. Insert the two woodruff keys, provided in the EA-3000IC Hardware Kit, into the key slots on the Impulse Coupled MTH Shaft. See Figure 3.



**Figure 3: Impulse Coupled MTH Shaft with Woodruff Keys Inserted. Step 4b**

- c. Install the impulse coupler or faux Impulse Coupler provided in the EA-3000IC Hardware Kit on to the Impulse Coupled MTH shaft. Be sure to align the slot in the coupler with the Woodruff key(s) on the shaft. See Figure 4 for a picture of this step.



**Figure 4: Impulse Coupler and Faux Impulse Coupler Installed. Step 4c**

- d. Install the drive gear onto the installed coupler on the shaft of the MTH. See Figure 5 for a picture of this step.



**Figure 5: Drive Gear installed on MTH. Step 4d**

- e. From the EA-3000IC Hardware Kit, Install the large washer onto the drive gear. Then install the smaller washer on top of the large washer. Next tighten the castle nut onto the shaft to 160-190 in-lbs<sup>1</sup>. Install the cotter pin through the castle nut and impulse coupled MTH shaft with the long end of the cotter pin

<sup>1</sup> AC 43.13-1B Table 7-1, 09/08/98

facing away from the MTH. Bend the long end of the cotter pin over the end of the shaft and the short end along the side of the nut. The drive gear is now installed onto the impulse coupled MTH shaft. See Figure 6 for visual install order of components.



**Figure 6: Install Order of Components to Impulse Coupled Shaft.**

- f. Holding the Impulse Coupled MTH, insert the alignment pin in the alignment hole on the back cover (pin supplied with hardware kit). Slowly turn the gear on the front of the unit until the alignment pin drops into a second hole inside the MTH. The MTH is now set to Top Dead Center (TDC) and the MTH shaft should not be able to spin. Leave the alignment pin in the MTH and ready the engine for the Impulse Coupled MTH installation (next steps). See Figure 2 for an example.
- g. Clean magneto pad on the engine. Install new gasket on p/n: EA-3000IC.
- h. **VERIFY MASTER SWITCH IS OFF AND BATTERY IS DISCONNECTED.**
- i. Rotate the engine to Top Dead Center (TDC) for cylinder # 1. This done by rotating the prop ***in the direction of the engine rotation*** until TDC is reached. Verify TDC using the timing marks found on the engine. Typically, the first set is on the fly wheel and the starter; they will line up at TDC; the second set may be another mark on the back-side of fly wheel which lines up with the engine case seam at TDC. If any of these indications are not correct, repeat this step until they are. Other safe methods for obtaining TDC may be used, such as observing the cylinder movement through the spark plug holes ***Always rotate the engine in the direction that it rotates during operation.***
- j. Install the Impulse Coupled MTH into the proper magneto hole. Secure the MTH using the MAG holding clips referenced in step 2e and secure per engine manufacturer specifications.
- k. **REMOVE THE ALIGNMENT PIN.** Failure to remove the MTH Alignment Pin may cause damage to the Impulse Coupled MTH, the engine, or both.
- l. P/N EA-3000IC is now installed and timed properly.
- m. If installing a 2nd EIS-41000IC for dual EIS, repeat steps 4a-4l for 2nd EA-3000IC.



## 5. Set-up & Installation of p/n: EA-24000(LH) MTH

- a. Retrieve p/n: EA-24000 or EA-24000LH MTH and the EA-24000(LH) MTH Hardware Kit.
- b. Holding the MTH, insert the alignment pin in the alignment hole on the back cover (pin supplied with hardware kit). Slowly turn the gear on the front of the unit until the alignment pin drops into a second hole inside the MTH. The MTH is now set to Top Dead Center (TDC) and the MTH shaft should not be able to spin. Leave the alignment pin in the MTH and ready the engine for the MTH installation (next steps). See Figure 7 for an example.



Figure 7 Installation of MTH Alignment Pin

- c. Clean magneto pad on the engine. Install new gasket on p/n: EA-24000(LH).
- d. **VERIFY MASTER SWITCH IS OFF AND BATTERY IS DISCONNECTED.**
- e. Rotate the engine to Top Dead Center (TDC) for cylinder # 1. This done by rotating the prop ***in the direction of the engine rotation*** until TDC is reached. Verify TDC using the timing marks found on the engine. Typically, the first set is on the fly wheel and the starter; they will line up at TDC; the second set may be another mark on the back-side of fly wheel which lines up with the engine case seam at TDC. If any of these indications are not correct, repeat this step until they are. Other safe methods for obtaining TDC may be used, such as observing the cylinder movement through the spark plug holes. ***Always rotate the engine in the direction that it rotates during operation.***
- f. Install the MTH into the proper magneto hole and connect correctly with the magneto drive gear retainer and cushions. Electroair recommends using new magneto drive cushions. See Figure 8.

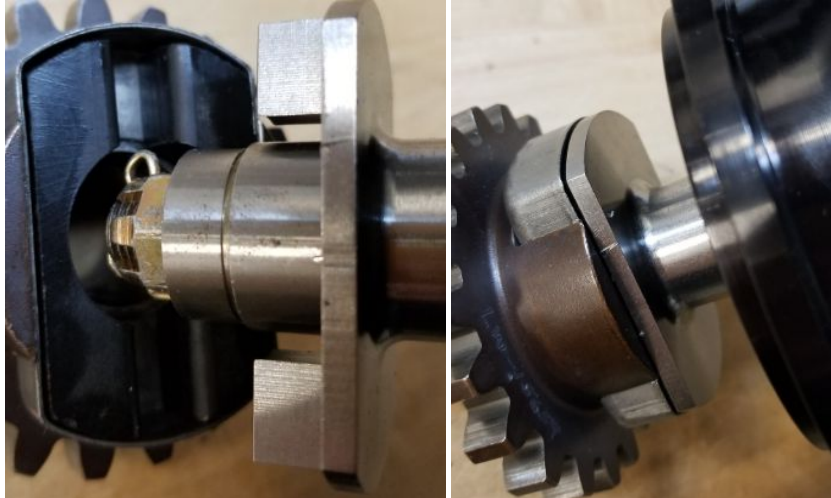


Figure 8: MTH Installation into magneto drive gear/cushions

- g. Secure the MTH using the mag holding clips referenced in step 2d and secure per engine manufacturer specifications.
- h. **REMOVE THE ALIGNMENT PIN.** Failure to remove the MTH Alignment Pin may cause damage to the MTH, the engine, or both.
- i. P/N EA-24000(LH) is now installed and timed properly.

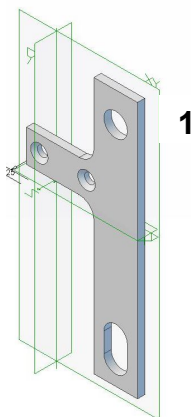
**6. Set-up & Installation of p/n: EA-9000A CSTW kit:**

- a. Retrieve p/n: EA-9000A CSTW kit (if included with the EIS-41000 series kit).
- b. Access is needed to the crankshaft between the engine case and the prop flange. Refer to engine manufacturer instructions to remove those components necessary to gain access.
- c. Clean the crank area just in front of the crank shaft seal. **CAUTION:** The exposed portion of the crank shaft is tin plated. Electroair Acquisition Corp. recommends using a liquid cleaner/degreaser. Do not use an abrasive (like sand paper or scotch-brite); this will remove the plating. Refer to engine manufacturer's maintenance instructions for proper procedure.
- d. **Lycoming Installations (Magnetic Pick-Up Bracket Installation)**
  - i. Temporarily fit the CSTW on the crank with the trigger wheel (timing teeth) toward the engine case. Slide the CSTW toward the prop flange (Silver side of the CSTW to the engine case, black side to the propeller). Maintain a minimum distance between the engine case and CSTW of 0.100".

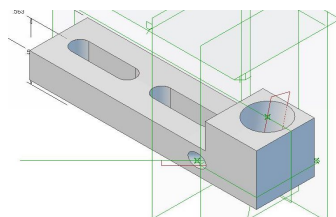


Figure 9: Typical installation of CSTW on a Lycoming 540 engine. Picture shows orientation of trigger wheel and typical bracket location. Please contact Electroair Tech Support if there are any questions about the assembly.

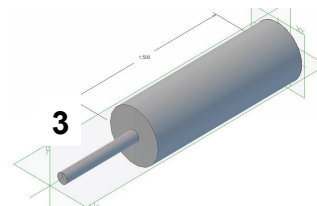
Figure 9



1



2



3

Figure 10: Components that make up the Lycoming CSTW Sensor Bracket; 1. Pick-Up Bracket; 2. Pick-Up Holder; 3. Magnetic Pick-up (Magnetic Sensor); hardware is not shown for clarity.

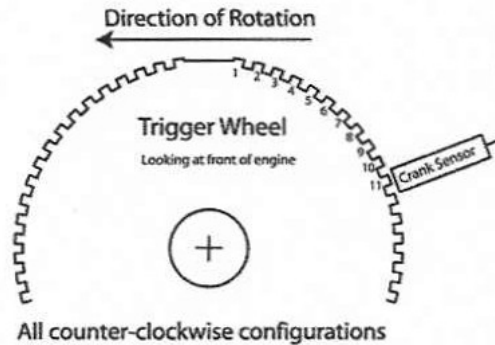
Figure 10

- ii. Temporarily install the pick-up Bracket Stand-Offs: Remove the forward journal bolt nuts and install the Bracket Stand-Offs supplied in the CSTW kit (see Figure 9); torque Stand-Offs to the same value as the nuts that were removed (300 in-lbs, per Lycoming manual).
- iii. Install Pick-Up Bracket using supplied socket head cap screws; torque screws to a value of 300 in-lbs. NOTE: Bracket may have to be removed to be able to install Pick-Up Holder; once bracket is in place and will not be removed, safety wire the cap screws in place.
- iv. Temporarily install the Sensor Holder on to the Pick-Up Bracket; leave the nuts loose enough so the Sensor Holder can slide back and forth to obtain the correct position.
- v. Position the CSTW so that the magnetic pick-up (sensor) would be oriented correctly on the timing teeth on the CSTW.
- vi. Rotate the CSTW and align the hole in the CSTW with the alignment tool (dowel/rivet assembly). Complete this by inserting the shaft of the pop rivet through the hole in the wood dowel. Place this assembly into the hole of the Pick-Up Holder (dowel/rivet assembly simulates a magnetic pick-up and pop rivet will serve as an alignment pin). Hold it in place.
- vii. While holding these pieces together, mark the position of the Pick-Up Holder on to the Pick-Up Bracket.
- viii. After marking the location of the Pick-Up Holder, remove the Pick-Up Bracket and Holder assembly; tighten the fasteners so the Pick-Up Holder is in the correct location on the bracket.
- ix. Re-attach completed magnetic Pick-Up Bracket/Holder assembly to the engine (install bracket assembly on stand-offs); tighten fasteners to the recommended torque values found in the engine overhaul specifications. **Verify that screws holding bracket to stand-offs have been secured using safety wire.**
- e. Verify that the master switch is off and battery is disconnected. Verify that the mag switch is off and the mag is properly grounded.



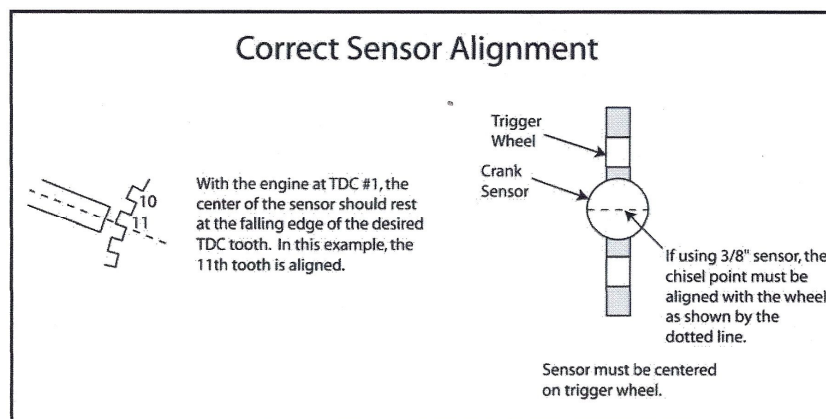
## **ALWAYS STAY OUT OF THE PROPELLER ARC!**

- f. Rotate the engine until number one cylinder is on Top Dead Center (TDC).
- g. Loosen the CSTW and rotate it until the alignment pin (remember the dowel/pop rivet assembly which is still in the pick-up holder) lines up with the hole in the CSTW. The alignment pin can be used to lock the CSTW position. **This should place the trailing edge of the 11<sup>th</sup> tooth past the two missing teeth** directly under the center of where the magnetic pick-up will go. Reference Figure 11 for sensor alignment and positioning.



**Figure 11: Crank Shaft Trigger Wheel Positioning**

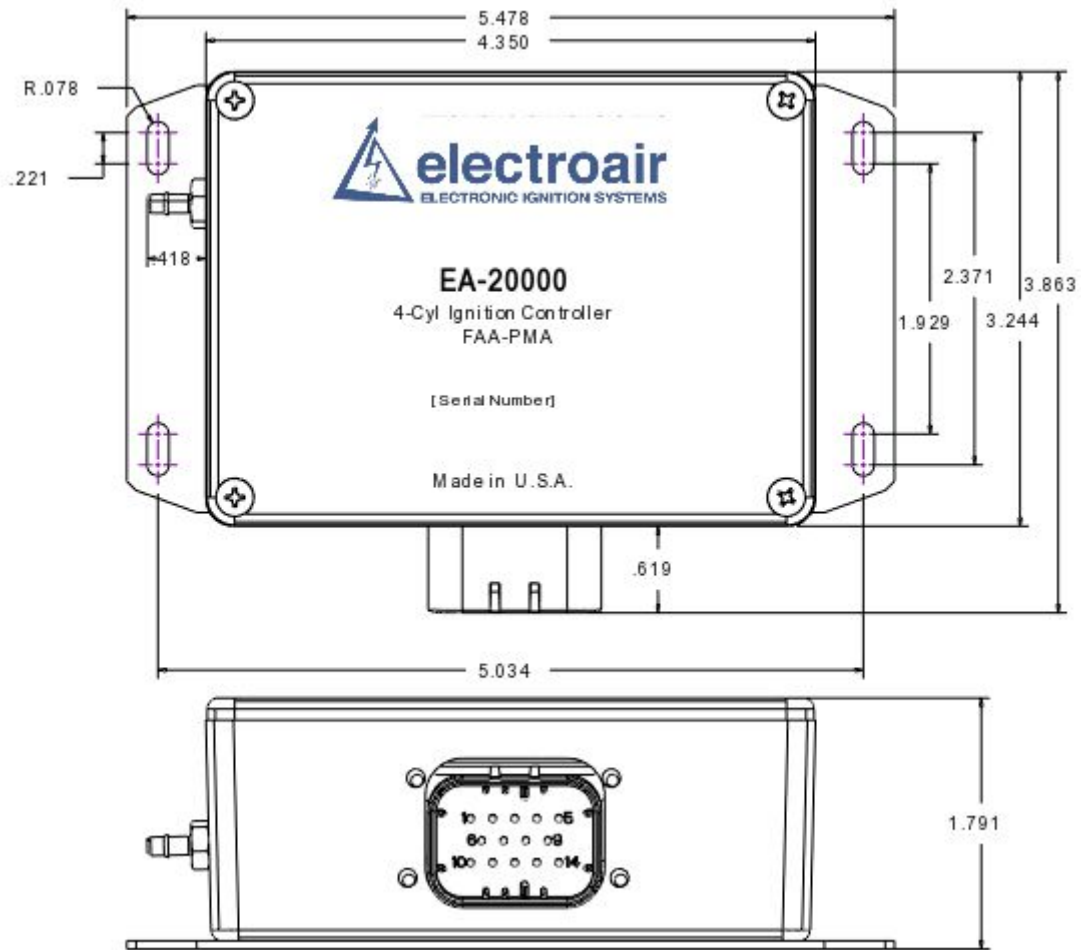
- h. Remove CSTW and apply Loctite (Loctite #242) to the crank shaft side of CSTW and to the two socket head cap screws.
- i. Carefully replace the collar to the crank shaft and line up using the alignment pin as a described in step g. The alignment pin will help hold the CSTW in position.
- j. Torque the cap screws on the CSTW to 20-25 inch-pounds. Be very careful that the gap between the two collar halves remains equal on both sides. If this gap is not held constant, the CSTW will not be concentric around the crank shaft and the timing pick-up will not function properly. **CAUTION:** Do not tighten the CSTW screws to the point that there is no gap between the collar halves. This means that the screws are over torqued, the aluminum collar stretched, and the CSTW will need replacing.
- k. Route the magnetic pick-up wire harness up the center of the engine case and then on top of the engine. Use cable ties as necessary to secure routing. **Do not route near spark plug wires. Do not tie wrap to ignition leads.**
- l. Remove the dowel/pop rivet assembly from the pick-up holder and install the magnetic pick-up. Using a feeler gauge or equivalent, set the gap to 0.024 inches. Once the gap between the timing teeth and the magnetic pick-up is set, apply a thin coating of Loctite #242 to the set-screws, insert them into the pick-up holder, and tighten them down. Remove the feeler gauge. **NOTE:** The tip of the sensor is a “Chisel Point”; this chisel must be positioned so that it is perpendicular to the plane of the trigger, or so that the chisel is parallel to the line of flight. See Figure 12.



**Figure 12: Correct Sensor Alignment**

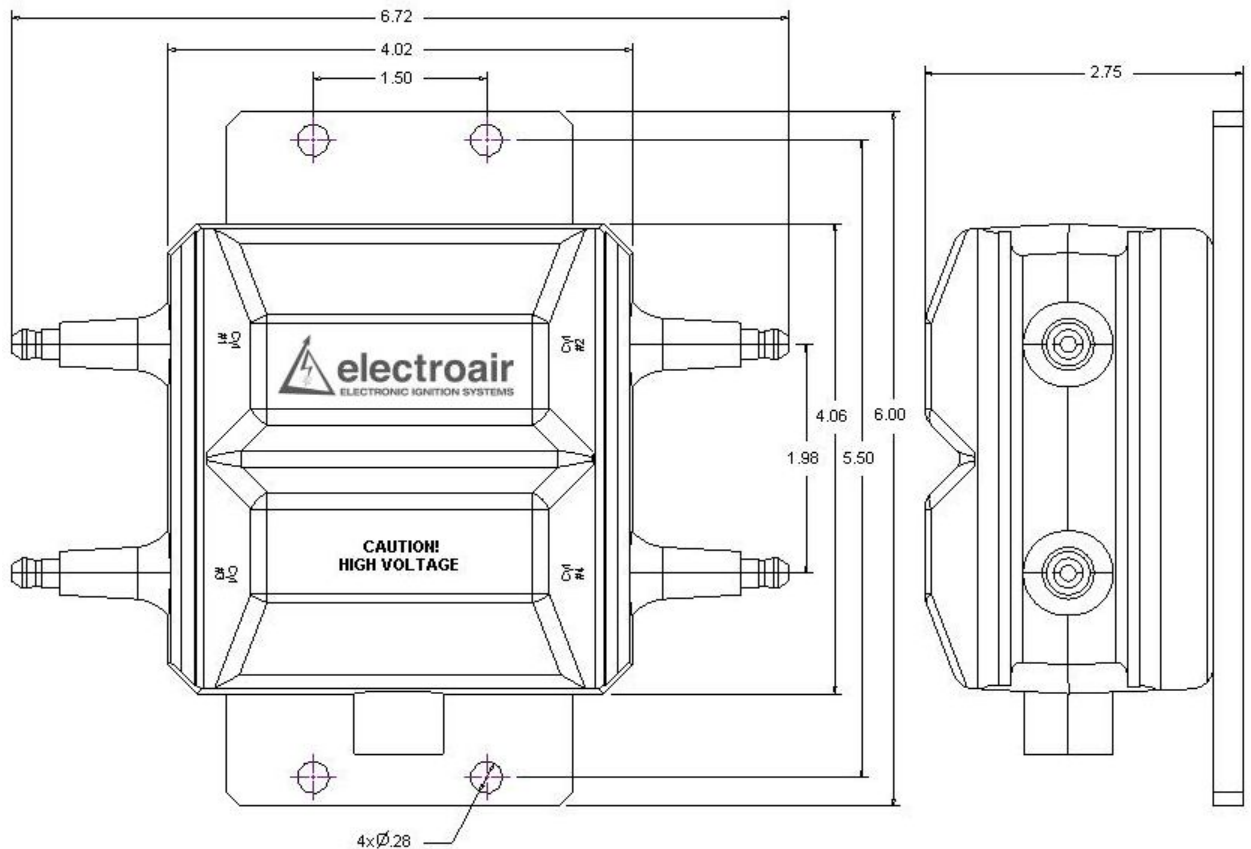
**7. Installation of p/n: EA-20000 EIS Controller and p/n: EA-2000 Coil Pack:**

- a. **EA-20000 Installation:** Install p/n EA-20000 EIS Controller where temperatures will not exceed 150°F. Because of this, Electroair recommends that the EIS Controller be mounted on the cockpit side of the firewall with the shortest practical distance from the coil pack for the wiring harness runs. Reference Figure 13 for controller dimensions.
- b. Use standard hardware to attach secondary ground wire from the exposed metal mounting hole on the EA-20000 to a competent airframe ground. A standard #6 screw will fit in the mounting hole.



**Figure 13: P/N EA-20000 Overall and Hole Dimensions**

- c. **EA-2000 Installation:** The coil pack is designed to be installed on the engine side of the firewall. Locate the unit in a position to keep the spark plug wires as short as possible and not interfere with other components or create maintenance difficulties in the future. Electroair strongly suggests that the Coil Pack be positioned so that the connector on the coil is facing straight down, but it can be positioned in any orientation if the installation requires alternate positioning. See Figure 14 for the Coil Pack Dimensions.



**Figure 14: P/N EA-2000 Dimensions**

- d. P/N EA-2000 comes with the mounting plate disassembled from the coil pack. This is done so the mounting plate can be used as a guide for easily locating mounting holes. When the mounting holes have been located, reinstall the plate to the coil pack following the procedure below:
- i. Obtain the mounting plate, coil pack, six mounting screws, and Loctite #242 (included in the EIS-41000 kit box).
  - ii. Align the six clearance holes on the coil plate so that they line up with the six threaded inserts on the coil pack. Make sure that the countersink, on the plate, is facing outward.
  - iii. Apply a small drop of Loctite #242 to each of the coil mounting screws and install plate to coil pack. Make sure that that plate is straight and tighten

screws (recommended torque value is 20-25 in-lbs<sup>2</sup>). **Note:** Try turning each screw a little bit at a time, instead of turning one screw all the way down, to help the plate align with the coil pack.

- iv. The black wire that is attached to the mounting plate should be attached to a competent airframe ground.



**CAUTION: Prior to any drilling, verify that there is clearance from any components on both sides of the firewall.**

- e. After all considerations have been made regarding the placement of the controller and the coil pack, drill the mounting holes and install both units using standard AN hardware. **NOTES:**
  - i. To avoid any firewall cracking, place large washers between the firewall and fastening nuts to reinforce these contact points.
  - ii. For honeycomb firewall installations, consider placing internal screw grommets inside the firewall around the mounting hardware to help prevent damage to the honeycomb structure.
  - iii. For Dual EIS Installations, consider where two EA-20000 controllers and two EA-2000 coil packs will be placed. When determining locations, consider that the controllers should be connected to the coil packs from their respective kits.
- f. For Dual EIS Installations, repeat steps 7a-7e to install the EA-20000 and the EA-2000 from the 2<sup>nd</sup> EIS kit.

---

<sup>2</sup> AC 43.13-1B Table 7-1, 09/08/98



## **8. Connection of Manifold Pressure Line:**

- a. Variable timing function using manifold pressure is optional. If variable timing is not desired or unable to be utilized, then the EA-20000 controller must be returned to Electroair for correct configuration. If variable timing is desired, proceed to step b.
- b. Verify that a manifold pressure line exists from the engine. If one exists proceed to step d.
- c. If a manifold pressure line does NOT exist, then one will need to be installed for variable timing to be used. This is Electroair's recommended procedure.
  - i. Select an appropriate source for MAP on the engine. For Continental and Lycoming engines, an unused primer port is acceptable source for MAP.
  - ii. Remove the plug from the unused primer port. Verify the thread size going into the primer port or other MAP source (typically 1/8" NPT). Select an appropriate fitting (we recommend for a straight nipple AN816-2D; for a 90° nipple, use AN822-2D).
  - iii. Fabricate and attach aluminum hardline to the nipple now installed in spare primer port.
  - iv. Route hardline to firewall bulkhead fitting (we recommend for a straight fitting AN832-2D).
  - v. On the cool side of the firewall, from the bulkhead fitting, route a flexible hose to the controller and attached hose to the EIS controller (EA-20000/EA-21000). We recommend using Stratoflex p/n: 193-2 or Aeroquip p/n: 306-2 flexible hose. Use correct swivel fitting for connection to bulkhead fitting; use standard hose clamps to secure flexible line to EIS controller.
  - vi. Check new lines for leaks before proceeding. Correct leaks as necessary.
- d. Now connect the manifold pressure line to bulkhead connector on the EA-20000. Make sure the connection is tight using hose clamps.
- e. For Dual EIS, connect the manifold pressure line to the bulkhead connector on both EA-20000s.
- f. If a Manifold Pressure gauge is installed, a "T" fitting can be placed into the manifold pressure line that is feeding the Manifold Pressure gauge.
  - i. The size of the bulkhead connector is 1/8 inch. Recommend Aeroquip 306 or Stratoflex 193 hose with 1/8inch ID.
  - ii. The manifold pressure line may be connected with either standard fittings or other appropriate fittings for this application, in accordance with F.A.R 43.13.
  - iii. Verify that all connections and lines are tight and secure.

## **9. Installation of p/n: EA-4000 Spark Plug Harness:**

- a. Install the spark plugs that will be connected to the Electronic Ignition System. Electroair recommends using new aircraft spark plugs. If re-using the old spark plugs, make sure that they are clean.
  - i. **Optional:** Electroair has approved wide gap aircraft spark plugs for use the Electroair Electronic Ignition Systems. These spark plugs are manufactured with the wider air gap Electroair recommends be used with the Electronic Ignition Systems. These Electroair spark plugs are not included in the standard EIS Kit. These plugs are only approved to be used with Electroair's Electronic Ignition Systems. The Electroair part numbers and descriptions for these plugs are below:
    - 1.) ***EARHB32E Massive Electrode Spark Plug:*** This plug is Electroair's version of the standard RHM32E spark plug. The EARHB32E plug is manufactured with a 0.036 inch air gap. The EARHB32E spark plug can be installed on the engines that are approved for the RHB32E spark plug, but can only be operated by an Electroair EIS. Please contact Electroair or one of our distributors for current pricing and availability of this spark plug.
    - 2.) ***EARHB32S Single Fine Wire Spark Plug:*** This plug is Electroair's version of the standard RHB32S spark plug. The EARHB32S is manufactured with a 0.036 inch air gap. The EARHB32S spark plug can be installed on the engines that are approved for the RHB32S spark plug, but can only be operated by an Electroair EIS. Please contact Electroair or one of our distributors for current pricing and availability of this spark plug.
    - 3.) ***EAREM37HE Massive Electrode Spark Plug:*** This plug is Electroair's version of the standard REM37BY spark plug. The EAREM37HE plug is manufactured with a 0.036 inch air gap. The EAREM37HE spark plug can be installed on the engines that are approved for the REM37BY spark plug, but can only be operated by an Electroair EIS. Please contact Electroair or one of our distributors for current pricing and availability of this spark plug.
    - 4.) ***EARHM38SE Single Fine Wire Spark Plug:*** This plug is Electroair's version of the standard RHM38S spark plug. The EARHM38SE is manufactured with a 0.036 inch air gap. The EARHM38SE spark plug can be installed on the engines that are approved for the RHM38S spark plug, but can only be operated by an Electroair EIS. Please contact Electroair or one of our distributors for current pricing and availability of this spark plug.
  - ii. For all other aircraft spark plugs, Electroair recommends that opening the gap of the spark plugs to 0.028 - 0.036 inches. For Lycoming engines, Electroair suggests using the REM37BY (or UREM37BY) spark plug because they are the easiest to gap. Refer to manufacturer's maintenance instructions on how to adjust gap. Check the engine application data to verify that these plugs can be used in the engine.



**CAUTION:** Be careful when gapping any plugs other than the REM37BY (UREM37BY) plug, because the outer electrode can become over-stressed and break. If any problems arise with plug

- selection, please contact Electroair ([sales@electroair.net](mailto:sales@electroair.net) or 248-674-3433).
- b. The kit came with two spark plug wire bundles. Each bundle will make two spark plug wires (four wires for single EIS). **Note:** The EIS kit comes with an EA-4000 REM Hardware Kit. If RHM or RHB spark plugs are being used, please contact Electroair for replacement hardware.



**CAUTION:** Since each assembly makes two spark plug wires, be careful when determining spark plug wire length.

- i. Route the spark plug wire from the coil pack to the correct cylinder (See Coil Pack label for wire orientation) to determine the spark plug wire length. Make sure to keep spark plug wire routings away from exhaust pipes and sensor wires. Spark plug wires routed parallel to each other require a minimum of 1/4 inch of separation.
- ii. Cut the spark plug wire leaving enough length to go three inches beyond the spark plug.
- iii. Slide the aluminum nut, receptacle, and gasket on the wire. See Figure 15 for the correct component stack-up.
- iv. The wire supplied is a spiral core wire with a non-conductive center. Insert the spark plug spring on the outside of the spiral core so that the spring 'tail' makes contact with the spiral core. The spring 'tail' should be felt as it hits the spiral core during the insertion.



**CAUTION:** do not install the spring tail directly in the center of the non-conductive material as it will not make contact with the spiral core.

**OPTIONAL:** ~1/8 inch of the ignition wire insulation may be stripped to expose the spiral core wire to make installing the spring easier.

- v. Verify continuity of the wires prior to install. Blue Wire (p/n EA-4090) resistance is 350 ohms/ft  $\pm$ 10%. Red Wire (p/n EA-4091) resistance is 5700 ohms/ft  $\pm$ 10%.

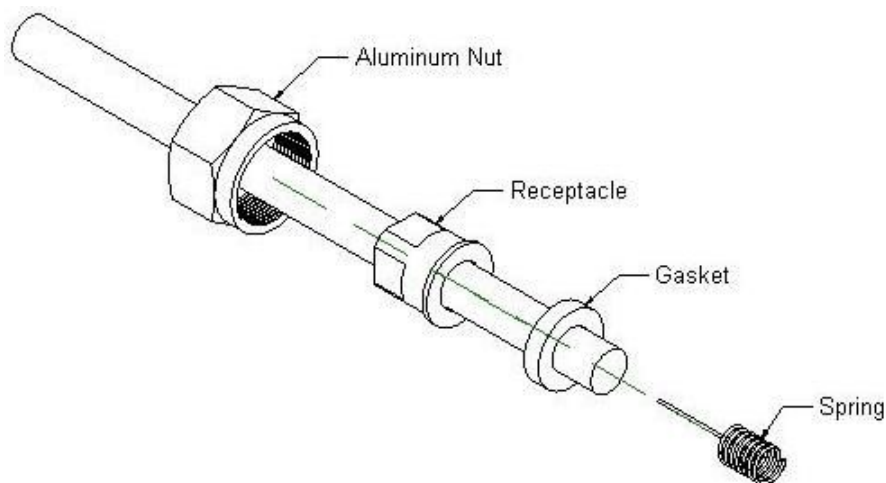


Figure 15: Spark Plug Wire Hardware Assembly

**NOTE:** For assistance with Spark Plug Wire Assembly, you can go to <http://www.electroair.net/>. Under Tech Support and Troubleshooting there is a link to a video that provides a helpful demonstration for Spark Plug Wire Assembly.

- vi. To finish the connection, install the spark plug end of the wire first. This prevents the spark plug wire from twisting as the spark plug nut is tightened.



**CAUTION:** Do not over-tighten the spark plug nut as this may cause separation of the core of the wire. Torque 5/8-24 spark plug hardware to 90-95 in-lbs<sup>3</sup>. Torque 3/4-20 spark plug hardware to 110-120 in-lbs<sup>3</sup>.

- vii. Repeat steps i through vi for each wire.
- c. Attach the other end of the spark plug wires to the coil pack at their appropriate coil tower. **NOTE:** When inserting the 90° boot over each tower on the coil pack, an audible “SNAP” should be heard when the wire is properly installed onto each tower. If this snap is not heard, remove the boot from the tower and repeat this step until the “SNAP” is heard.
  - i. Coil towers are numbered on the coil pack: 1, 2, 3, and 4. Because of the nature of the system, coil towers 1 & 2 will fire simultaneously and then coil towers 3 & 4 will fire simultaneously.
  - ii. For Lycoming and Continental engines, hook-up the spark plug wires according to the following chart:

<b>Coil Pack</b>	Tower 1	Tower 2	Tower 3	Tower 4
<b>Cylinder #</b>	1	2	3	4

- iii. The coil towers should be oriented towards the same side of the engine as the cylinders – this should make spark plug wire hook-up easier.
- d. For Dual EIS installations, repeat steps 9a-9c for each EIS kit’s spark plug wires.

---

<sup>3</sup> Bendix Ignition Manual

## 10. Connection of p/n: EA-22000 Wiring Harness:

- a. **Verify that the master switch is off and battery is disconnected.**
- b. The electrical connections that will be made are as follows:
  - i. Harness to p/n: EA-20000, EIS Controller
  - ii. Harness to p/n: EA-3000, EA-3000LH, EA-3000IC, EA-3000LHIC, EA-24000, EA-24000LH Mag Timing Housing (MTH) or EA-9000A CSTW
  - iii. Harness to Tachometer
  - iv. Harness to Switched Power & Ground for EIS Controller
  - v. Harness to p/n: EA-2000, Coil Pack
  - vi. Harness to Ignition Switch (Rotary Switch Only)
- c. **For Dual EIS Installation:** Refer to page 8 for Dual EIS Limitations and Requirements for Installation. Dual EIS refers to two EIS kits installed independently on one engine.
  - i. **Dual Electrical System Option:** Typically, there are two separate electrical busses on aircraft equipped with dual electrical systems. Using this option, wire one EIS to each separate electrical bus (steps 10.i.vi and 10.j.iii). Follow steps 10d through 10l for each EIS (follow steps twice, once for each EIS). Electrical systems must be able to support a 12 volt, 1.5 amp, or 24 volt, 0.8 amp load for one EIS, and 12 volt, 3.0amp or 24 volt, 1.6 amp for two EISs.
  - ii. **Backup Alternator/Generator System Option:** Follow steps 10d through 10l for each EIS (follow steps twice, once for each EIS). Select which EIS will be connected to the backup alternator (only one required). Attach that EIS to the backup alternator directly such that the EIS will continue to be powered by the backup alternator in the event of a primary electrical system failure. Attach the other EIS to the essential bus. Refer to backup alternator installation instructions for direct backup of electrical equipment to alternator. Backup alternator must be able to support a 12 volt, 1.5 amp, or 24 volt, 0.8 amp load. **Note:** Form EAF-0526, Backup Alternator Load Analysis, must be completed, reviewed, and accepted before STC Authorization of Dual EIS install.
- d. A small hole must be installed in the fire wall to route wires from the harness to their intended connections. Electroair recommends a 1-inch diameter hole be drilled to provide clearance for the wire harnesses. A grommet, suggested p/n: MS35489-12, can be used to help seal off the firewall hole after the wire harness has been passed through the firewall.



**CAUTION:** *Prior to any drilling, verify that there is clearance from any components on both sides of the firewall.*

- e. **NOTES:** The main harness is assembled so it can be installed through tight clearances such as a hole in the fire wall. A supply of terminations for switches, circuit breakers, and the bus bar will be needed. A wiring diagram with pin-out information has been supplied at the end of this section for reference. Refer to AC 43.13 regarding the bend radii of wires.



**CAUTION:** Follow these wiring instructions very carefully to insure a correct hook-up of the EIS. Skipping ahead or taking short cuts increases the risk of an incorrect installation and either a poor performing EIS or the possibility of damaging equipment. Please contact Electroair with any questions.



**CAUTION:** Make sure that wires are separated away from the spark plug wires. High voltages going through the spark plug wires can interfere with signals going through sensor and power wires.

f. **Harness to p/n: EA-20000, EIS Controller:**

- i. Connect the wiring harness assembly to the EIS Controller. This is done by inserting the 14-pin female connector (**C1**) into the male header on the Controller. Begin routing the various harness bundles and wires from here.



Figure 16: C1 Connector

g. **Harness to p/n: EA-3000, EA-3000LH, EA-3000IC, EA-3000LHIC, EA-24000, EA-24000LH Mag Timing Housing (MTH) or EA-9000A CSTW:**

- i. Route the harness with the square BLACK three pin connector (**C3**) to the EA-3000, EA-3000LH, EA-3000IC, EA-3000LHIC, EA-24000, EA-24000LH MTH or EA-9000A CSTW.
- ii. From the already installed MTH/CSTW, there will be a wire harness terminated with a female square BLACK three pin connector. See Figure 17.

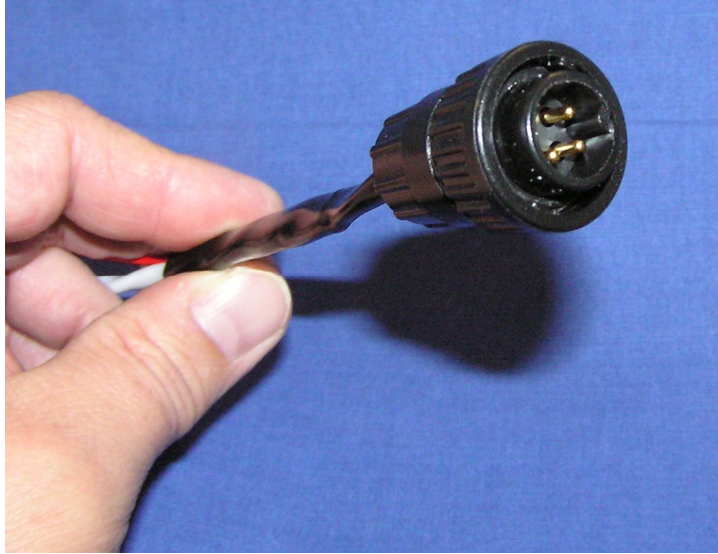


Figure 17: MTH and 3 Pin Female Connector

- iii. Connect connector from the routed harness to the connector on the MTH/CSTW. Verify that the connection is secure. Connectors should ‘snap’ together and be unable to fall apart from each other on their own.
  - iv. Loop any excess wire and secure with cable ties.
- h. Harness to Tachometer:**
- i. The EIS has an optional electronic tach signal available and can be used with an electronic tachometer. If the signal is to be used, follow the next instructions.
  - ii. Go to the harness connector that is installed on the Controller.
  - iii. Obtain the 22 gauge BLACK wire, labeled “ELECTROAIR TACHOMETER”, that is coming out of this connector at Pin 8.
  - iv. The Tachometer output signal is a 12V or 24V (dependent on aircraft system voltage) square wave with two pulses per revolution. **CAUTION:** Verify that the Tachometer or engine monitor system being used can receive the above signal before connecting and operating. Incorrect signal types can cause incorrect readings or potentially damage monitoring systems. Mechanical tachometers will not be able to receive the signal.
  - v. Route this BLACK wire to Tachometer or monitor system and install the lead as specified by the equipment manufacturer. Loop any excess wire and cable tie or clamp the loop to a convenient location that does not interfere with any components
  - vi. If this output is not intended to be used at this time, then this bundle should be looped and tied to an appropriate place inside the cockpit for later use. Alternatively, this wire can be trimmed out of the harness connector if this option will never be used.
- i. Harness to Switched Power & Ground for EIS Controller:**
- i. Go to the harness connector that is installed on the Controller.
  - ii. Obtain the RED wire that is coming out of this connector at Pin 6.
  - iii. Route the loose end of this RED wire to the panel for switch termination and circuit breaker termination (fuses may be used as an alternative to the breaker).
  - iv. Trim & Terminate the Red wire to a panel mounted switch. Label this panel mounted switch “EIS Switch”, and proper “ON/OFF” orientation. This switch should be a SPST switch.
  - v. Repeat steps i through iv for Dual EIS Installations.
  - vi.
    - 1.) **Single EIS Installation:** Connect the panel mounted switch to a 2-amp breaker or fuse. Connect the 2-amp breaker or fuse to Essential Bus Bar. See Figure 20.
    - 2.) **Dual EIS Installation with Dual Electrical System:** Connect each panel mounted switch to a 2-amp breaker or fuse. For one EIS kit, connect its 2-amp breaker or fuse to one Essential Bus Bar. For the other EIS, connect its 2-amp breaker or fuse to the other essential bus bar. **Note:** Keep track of what power source is connected to each EIS. See Figure 21.

- 3.) **Dual EIS Installation with Back-up Alternator:** Connect a panel mounted switch to a 2-amp breaker or fuse. For one EIS kit, connect that 2-amp breaker or fuse to the Essential Bus Bar. For the other EIS, connect the panel mounted switch to two separate current protection diodes. Current will need to flow into the EIS and not the other direction. From one of the diodes, connect to a 2-amp breaker or fuse and then to the essential bus bar. Connect the other diode to another 2-amp breaker or fuse and then to the back-up alternator. **Note:** Keep track of what power source is connected to each EIS. See Figure 22.
- vii. Go to the harness connector that is installed on the Controller.
- viii. Obtain the 16-gauge Black wire, labeled "ELECTROAIR GROUND", that is coming out of this connector at Pin 14.
- ix. Trim & Terminate the Black wire to a competent aircraft ground.
- x. **IMPORTANT:** For aircraft that are using the "EIS Switch" as the ignition switch for the EIS-41000 (or EIS-41000IC) and not a Rotary Style Grounding switch, follow these procedures:
  - 1.) Go to the harness connector that is installed on the Controller.
  - 2.) Obtain the shielded WHITE wire, labeled "ELECTROAIR KEY SWITCH P-LEAD", which is coming out of this connector at Pin 10.
  - 3.) Trim this wire out of the connector and discard. **NOTE:** Be careful not to nick or cut any of the surrounding wires in the connector when trimming out this wire.
- xi. Repeat steps vii through x for Dual EIS Installation.
- j. **Harness to p/n: EA-2000, Coil Pack:**
  - i. Route the harness with the round BLACK connector(C2) to the Coil Pack. This harness is terminated with a round plug type connector. See Figure 18 for how the harness should look. **CAUTION: There is a noise suppressor capacitor in the harness just below Coil Pack Connector (covered by heat shrink). Use extreme caution when routing this harness. DO NOT make sharp bends in the portion of the harness covered by the heat shrink. Make all bends past the heat shrink tube covered portion of the harness. This will prevent damage to the capacitor. Please call Electroair Tech Support if there are any questions.**





**Figure 18: Coil Pack Harness Plug (C2)**

- ii. Connect the **(C2)** connector from the harness to the mating connector on the Coil Pack.
- iii.
  - 1.) **Single EIS installation:** Route the unterminated end of the Red wire from the harness through a 10-amp breaker (fuses may be used as an alternative to the breaker) to the Essential Bus Bar. Trim and terminate as required. See Figure 20.
  - 2.) **Dual EIS installation with Dual Electrical System:** For each EIS, route the unterminated end of the Red wire from the harness through a 10-amp breaker (fuses may be used as an alternative to the breaker) to the same essential bus that the controller in the same EIS kit is connected too. Trim and terminate as required. See Figure 21.
  - 3.) **Dual EIS installation with Back-up Alternator:** For one coil pack, route the unterminated end of the Red wire from the harness through a 10-amp breaker (fuses may be used as an alternative to the breaker) to the same essential bus that the controller in the same EIS kit is connected too. Trim and terminate as required. For the other coil pack, route the unterminated end of the Red wire from the harness to two separate current protection diodes. Current will need to flow into the coil pack and not the other direction. From one of the diodes, connect to a 10-amp breaker or fuse and then to the essential bus bar. Connect the other diode to another 10-amp breaker or fuse and then to the back-up alternator. Trim and terminate as required. **Note:** This coil pack that is connected to the backup alternator should be in the same EIS kit as the controller that is connected to the back-up alternator. See Figure 22.
- iv. Loop any excess wire and cable tie or clamp the loop to a convenient location that does not interfere with any components (a location on the inside of the firewall is suggested).
- k. **Harness to Rotary Switch (if installed):**
  - i. For aircraft that use two separate ignition switches, go to installation step 9b
  - ii. Go to the harness connector that is installed on the Controller.

- iii. Obtain the shielded WHITE wire, labeled “ELECTROAIR KEY SWITCH P-LEAD”, which is coming out of this connector at Pin 10.
  - iv. Trim and terminate this shielded WHITE wire to the appropriate connection on the ignition switch. The appropriate connection on the ignition switch will be the connection that the replaced magneto P-lead was removed from. Use the same methods for terminating a Magneto P-Lead when terminating the EIS P-Lead. **IMPORTANT:** Make sure the shield on the EIS P-Lead wire is grounded. Failure to ground this shield can cause the EIS to not operate properly.
- I. Figure 19 shows the Wiring Diagram for the EIS-41000 & EIS-41000IC. Both EIS kits for a Dual EIS installation will have similar wiring. The only difference will be with one of the EIS kits being connected to a different essential bus or backup power source. See Figures 20-22 for power source connection options.
- i. **Single EIS installation:** The connection for C2-Pin 4 and C1-Pin 6 should be to the main essential bus (through 10A and 2A breaker or fuses). Figure 20.
  - ii. **Dual EIS installation using dual electrical systems:** Connect C2-Pin 4 and C1-Pin 6 of one EIS to one electrical system (through 10A and 2A breaker or fuses). Connect C2-Pin 4 and C1-Pin 6 of the 2nd EIS to the other electrical system (through 10A and 2A breaker or fuses). Figure 21.
  - iii. **Dual EIS installation using a backup alternator:** Connect C2-Pin 4 and C1-Pin 6 of one EIS to the main essential bus (through 10A and 2A breaker or fuses). Connect C2-Pin 4 and C1-Pin 6 of the 2nd EIS to the backup alternator and essential bus using current protection diodes (through 10A and 2A breaker or fuses). Figure 22

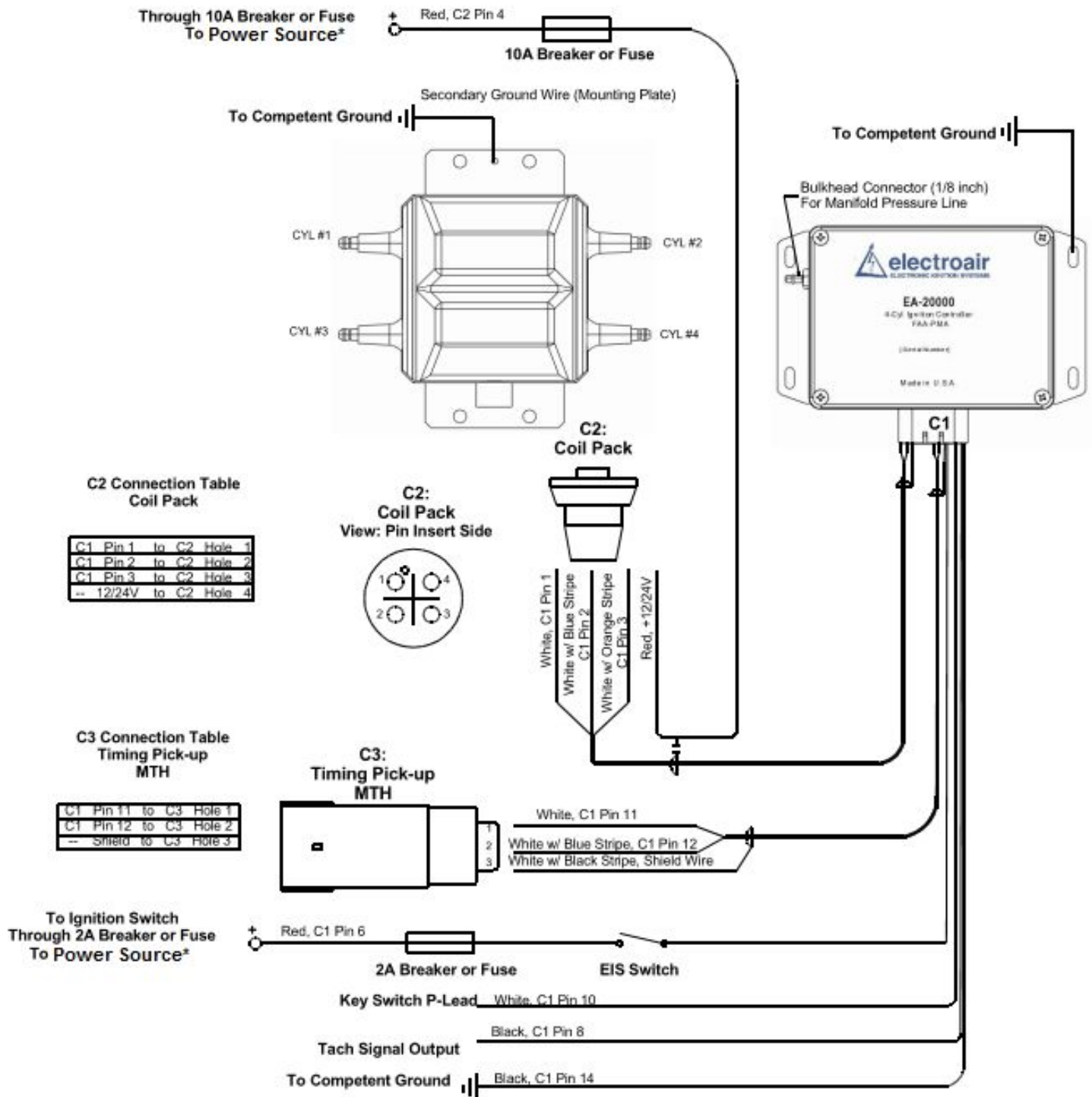


Figure 19: Wiring Diagram for EIS-41000 & EIS-41000IC

\* Power Source: See step 10I and Figures 20-22.

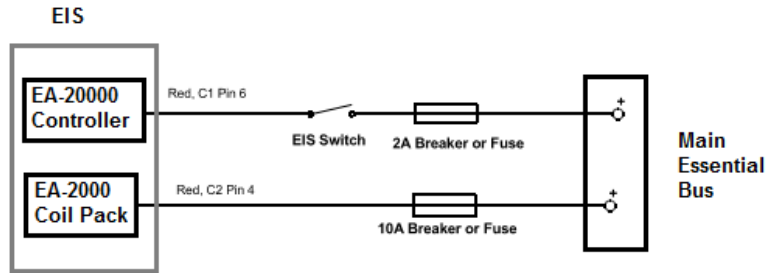


Figure 20: Single Engine, Single EIS Power Connection

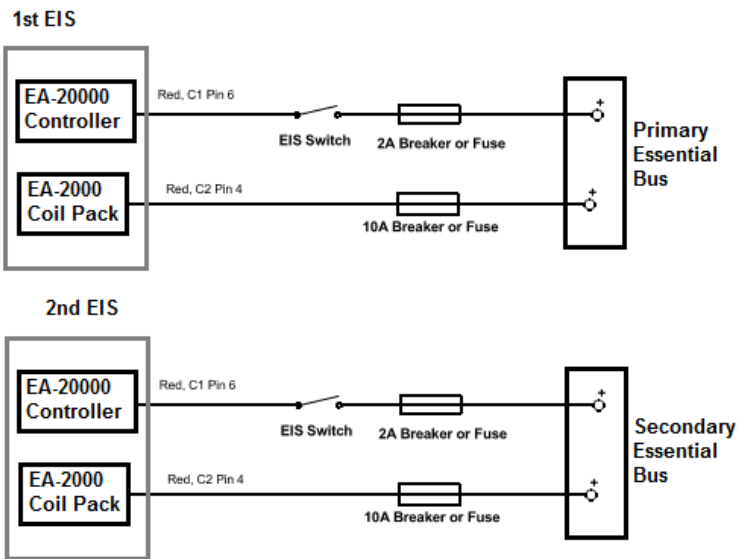


Figure 21: Single Engine, Dual EIS Dual Electrical System Power Connections

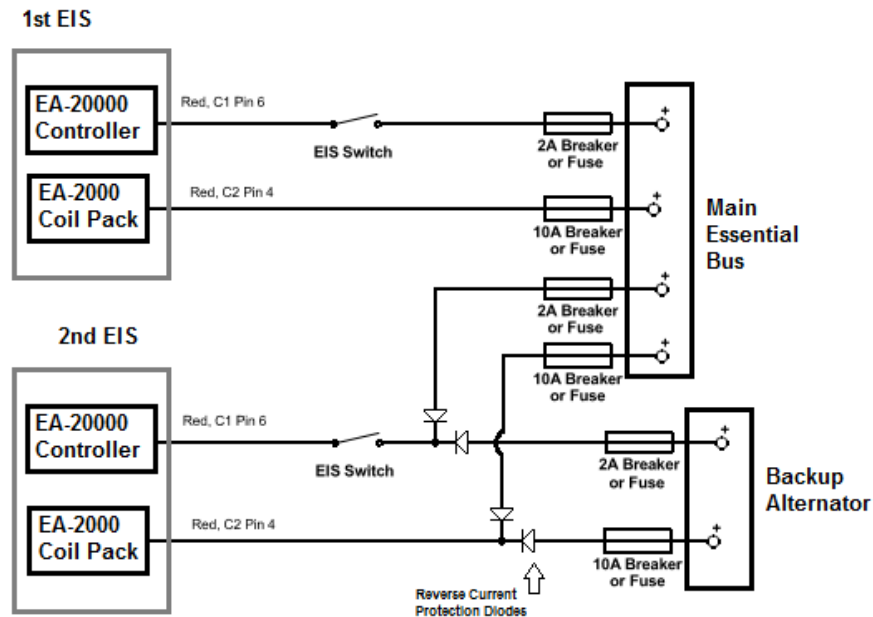


Figure 22: Single Engine, Dual EIS Backup Alternator Connections

## 11. Final Installation Steps:

- a. Calibration and Timing settings: The unit has been pre-set at the factory to a pre-determined base timing (base timing is always placarded timing for the engine). Please contact Electroair (248-674-3433 or [sales@electroair.net](mailto:sales@electroair.net)) if it is felt that the unit is not performing optimally, or if that base timing needs to be adjusted.
- b. **IMPORTANT:** For aircraft that are using the “EIS Switch” as the ignition switch for the EIS-41000 (or EIS-41000IC) follow these procedures:
  - i. Go to the harness connector that is installed on the Controller.
  - ii. Obtain the shielded WHITE wire, labeled “ELECTROAIR KEY SWITCH P-LEAD”, which is coming out of this connector.
  - iii. Trim this wire out of the connector and discard. **NOTE:** Be careful not to nick or cut any of the surrounding wires in the connector when trimming out this wire.
  - iv. Return to Wiring Harness install steps if necessary.
- c. Re-attach and reinstall any connections or components that were removed or loosened during this installation.
- d. Secure all new wires, harness, connections and lines to prevent failures due to vibration.
- e. Connect battery connections and close any open circuit breakers.
- f. Recover all tools that may have been used (tools ‘floating’ around inside the airplane are dangerous).
- g. Verify backup power sources are capable of supplying the required load to connected EISs. Note: Form EAF-0526, Backup Alternator Load Analysis, must be completed, reviewed, and accepted before STC Authorization of Dual EIS install.
- h. Using the Aircraft Flight Manual Supplement, AFMS EIS-41000 Revision 09 or later FAA approved revision, for the EIS, perform a test run-up before flying.

**12. Installation Options available from Electroair:**

- a. P/N: EAREM37HE. Electroair's Massive Electrode Spark Plug. This plug is Electroair's version of the standard REM37BY spark plug manufactured with a 0.036 inch air gap and has been approved for use with only Electroair's electronic ignition systems. These plugs come with the increased air gap Electroair recommends be used with our systems and eliminates the time and headache of re-gapping standard aircraft spark plugs. These Electroair spark plugs are not included in the standard EIS Kit. Please contact Electroair or one of our distributors for current pricing and availability of this spark plug.
- b. P/N: EARHM38SE. Electroair's Single Fine Wire Spark Plug. This plug is Electroair's version of the standard RHM38S spark plug manufactured with a 0.036 inch air gap and has been approved for use with only Electroair's electronic ignition systems. These plugs come with the increased air gap Electroair recommends be used with our systems and eliminates the time and headache of re-gapping standard aircraft spark plugs. These Electroair spark plugs are not included in the standard EIS Kit. Please contact Electroair or one of our distributors for current pricing and availability of this spark plug.

## Overview of Four Cylinder Twin Engine Aircraft EIS Installation

Thank you for purchasing Electroair Electronic Ignition Systems, or EISs, for twin engine aircraft. Electroair offers four optional EIS kits for four-cylinder twin engine aircraft. These EIS kits differ in the type of magneto they replace. Listed below are the part numbers for each EIS kit and a brief description of which magneto is replaced by the EIS kits.

- **EIS-41000T:** This EIS kit replaces the NON-impulse coupled magneto on the standard rotating engine of a twin engine aircraft.
- **EIS-41000TIC:** This EIS kit replaces the impulse coupled magneto on the standard rotating engine of a twin engine aircraft.
- **EIS-41000TLH:** This EIS kit replaces the NON-impulse coupled magneto on the counter-rotating engine of a twin engine aircraft.
- **EIS-41000TLHIC:** This EIS kit replaces the impulse coupled magneto on the counter-rotating engine of a twin engine aircraft.

**EIS Kit Notes:** One EIS kit can be installed on each engine of a twin engine aircraft or, with certain limitations, two EIS kits can be installed on each engine. Some twin engine aircraft do NOT have a counter-rotating engine, for that reason the EIS kits designated with an “LH” in their part number are not eligible for these aircraft type. The same part number EIS kit does NOT have to be installed on both engines on the twin engine aircraft.

The next several pages are a step-by-step process of installing both EIS’s on the aircraft. Electroair hopes that this manual will provide clear direction and guidance through this process. This manual will cover the following general installation steps:

1. General Overview and Recommendations
2. Removal of Old Ignition Components
3. Set-up & Installation of p/n: EA-3000 MTH (EIS-41000T Kit Only) and EA-3000LH MTH (EIS-41000TLH Kit Only)
4. Set-up & Installation of p/n: EA-3000IC MTH (EIS-41000TIC Kit Only) and EA-3000LHIC MTH (EIS-41000TLHIC Kit Only)
5. Set-up & Installation of p/n: EA-24000(LH) MTH
6. Set-up & Installation of p/n: EA-9000A CSTW Kit
7. Installation of p/n: EA-20000 EIS Controllers and p/n: EA-2000 Coil Packs
8. Connection of Manifold Pressure Line
9. Installation of p/n: EA-4000 Spark Plug Harnesses
10. Connection of p/n: EA-22000T Twin Engine Wiring Harnesses
11. Final Installation Steps
12. Installation Options Available from Electroair

Electroair strongly recommends reading through this entire installation procedure before installing the EIS’s on the aircraft. Make sure that any questions are answered before the actual installation. Also, make sure any extra components that needed, e.g. cable

ties, circuit breakers, switch terminations, etc., are all available. Removal of old components and installation of new components is to be completed in compliance with CFR Title 14 Part 43, as applicable, and any Airframe or Engine Manufacturer Maintenance Procedures, as applicable. Above all else, use good common sense and professional judgment. An electronic ignition system is a high voltage device. If an EIS is improperly installed, maintained, or misfired, severe damage may occur to the EIS, the aircraft, the engine, or even the installer.

Please contact Electroair with any questions during this installation process. Good luck and happy flying!!

Electroair



# ***Installation of EIS-41000T, EIS-41000TIC, EIS-41000TLH & EIS-41000TLHIC***

## **1. General Overview and Recommendations:**

- a. Read through the entire installation instructions before beginning the installation to make sure each step is understood. Contact Electroair (248-674-3433 or [sales@electroair.net](mailto:sales@electroair.net)) with any questions or if there are any items that are unclear.



## **VERIFY TIMING CONTROLLER PLACARD TO ENGINE PLACARD**

- b. If controller placarded timing does not match engine placarded timing, contact Electroair (248-674-3433 or [sales@electroair.net](mailto:sales@electroair.net)). The controller will need to be re-timed before installation.
- c. This ignition system is designed to be installed by aviation professionals with the appropriate ratings and experience for maintaining General Aviation aircraft.
- d. When installing all EIS components, if preexisting components on the airframe are in the way of or are in close proximity to the installation locations follow one of these two measures. **Note:** When making **ANY** changes or modifications to the aircraft or aircraft components, make sure all practices are in accordance with CFR Title 14 Part 43.
  - i. If the preexisting components can be relocated, move the components to an acceptable location on the airframe where they will not come into contact with the EIS component(s).
  - ii. If the preexisting components must come into contact or close proximity to the EIS component(s), make sure to protect all components from each other. This could mean, but not limited to, adding anti-chafing material, additional component securing devices, heat shielding material, etc.
- e. Always use good safety and work practices. Use appropriate safety equipment (glasses, etc.) and precautions. The EIS is a high voltage system and if installed or tested incorrectly can cause substantial damage to both the system and the installer!

## **2. Removal of Old Ignition Components:**

- a. Any removed articles that will be re-used (gears, impulse couplings) should be inspected for condition before re-installation.
- b. Remove cowlings. Verify that Master Switch is off and battery is disconnected.
- c. **IMPORTANT:** Determine which magnetos will be replaced, either the right or the left magneto, whether it is direct drive or impulse coupled magneto, and whether it is for a standard or counter-rotating engine.
  - i. When replacing a direct drive type magneto, the magneto will have single gear installed on its drive shaft. This gear will be reused to install either p/n: EA-3000 or EA-3000LH.
  - ii. When replacing an impulse coupled magneto, the magneto will have an impulse coupler installed on its drive shaft and a drive gear installed on top of the impulse coupler. The drive gear will be reused to install either p/n: EA-3000IC or EA-3000LHIC. **NOTE:** The impulse coupler will be needed for Continental engines. The impulse coupler will be used for its dimensions only, and not its functionality for retarding the spark on start-up. For Lycoming engines, a faux impulse coupler will be provided in the EA-3000IC hardware kit.
- d. Remove ignition harnesses from the spark plugs associated with the magnetos that are being replaced.
- e. Disconnect magneto P-leads from their respective ignition switches. Note: These ignition switches may be used later in the installation of the EIS Wiring Harnesses.
- f. Remove the selected magnetos, the selected magnetos' ignition harnesses, and selected magnetos' P-leads from both the engines and the airframe. Retain the magneto hold down clips; they will be used to install the MTH (either p/n: EA-3000, EA-3000LH, EA-3000IC, EA-3000LHIC, EA-24000, or EA-24000LH).
- g. Remove the magneto drive components, as detailed in step 2.b, from each magneto. Be careful not to damage the drive components. We recommend using a standard gear puller. Retain drive components for installation of either p/n: EA-3000, EA-3000LH, EA-3000IC, or EA-3000LHIC.
- h. Remove spark plugs if new plugs are going to be used (recommended) with the electronic ignition systems.
- i. For Dual EIS Installations, repeat steps a-g to replace the other magneto.
- j. For single-drive dual magneto replacement, please prepare the dual-magneto core for return to Electroair. With the core return, also include copies of the engine logbook showing when dual mag was installed and removed. Call Electroair if there are any questions.

### **3. Set-up & Installation of p/n: EA-3000 MTH (EIS-41000T Kit Only) and EA-3000LH MTH (EIS-41000TLH Kit Only):**

- a. Retrieve either p/n: EA-3000 or EA-3000LH and the EA-3000 Hardware Kit, depending on which EIS kit being installed.
- b. Insert the woodruff key into the key slot on the MTH shaft.
- c. Place the direct drive magneto gear on the MTH shaft. Be sure to align the woodruff key with the slot in the gear.
- d. Install the washer and nut onto the MTH shaft and tighten the nut to 300-340 in-lbs. Install the cotter pin through the castle nut and MTH shaft with the long end of the cotter pin facing away from the MTH. Bend the long end of the cotter pin over the end of the shaft and the short end along the side of the nut. The direct drive gear is now installed onto the MTH shaft.
- e. Holding the MTH, insert the alignment pin in the alignment hole on the back cover (pin supplied with hardware kit). Slowly turn the gear on the front of the MTH until the alignment pin drops into a second hole inside the MTH. The MTH is now set to Top Dead Center (TDC) and the MTH shaft should not be able to spin. Leave the alignment pin in the MTH and ready the engine for the MTH installation (next steps). See Figure 23 for an example.



Figure 23: Installation of MTH Alignment Pin on an EA-3000 MTH

- f. Clean magneto pad on the engine. Install new gasket on the MTH.
- g. **VERIFY MASTER SWITCH IS OFF AND BATTERY IS DISCONNECTED.**
- h. Rotate the engine to Top Dead Center (TDC) for cylinder #1. This done by rotating the prop ***in the direction of the engine rotation*** until TDC is reached. At TDC, the impulse coupler on the remaining magneto should click. Verify TDC using the timing marks found on the engine. **NOTE:** Consult engine manufacturer ICA for identifying number 1 cylinder and timing marks. Typically, the first set is on the fly wheel and the starter; they will line up at TDC; the second set may be another mark on the backside of fly wheel which lines up with the engine case seam at TDC. If any of these indications are not correct, repeat this step until they are. Other safe methods for obtaining TDC may be attempted, such as witnessing the cylinder movement through the spark plug holes. ***Always rotate the engine in the direction that it rotates during operation.***

- i. Install the MTH into the proper magneto hole. Secure the MTH using the mag holding clips referenced in step 2e and secure per engine manufacturer specifications.
- j. **Remove the alignment pin.** Failure to remove the MTH Alignment Pin may cause damage to the MTH, the engine, or both.
- k. P/N EA-3000 or EA-3000LH is now installed and timed properly.
- l. Repeat these steps for the second engine on the airframe for installing either p/n: EA-3000 or EA-3000LH on that engine.
- m. For Dual EIS installation, repeat steps 3a-3k and install the 2nd EA-3000 or EA-3000LH for each engine.

**4. Set-up & Installation of p/n: EA-3000IC MTH (EIS-41000TIC Kit Only) and EA-3000LHIC MTH (EIS-41000TLHIC Kit Only):**

- a. Retrieve either p/n: EA-3000IC or EA-3000LHIC and the EA-3000IC Hardware Kit, depending on which EIS kit being installed.
- b. Insert the two woodruff keys, provided in the EA-3000IC Hardware Kit, into the key slots on the Impulse Coupled MTH shaft. See Figure 24 for a picture of this step.



**Figure 24: Impulse Coupled MTH Shaft with Woodruff Keys inserted. Step 4b**

- c. Install the impulse coupler or faux impulse coupler provided in the EA-3000IC Hardware Kit on to the Impulse Coupled MTH shaft. Be sure to align the slot in the coupler with the Woodruff key(s) on the shaft. See Figure 25 for a picture of this step.



**Figure 25: Impulse Coupler and Faux Impulse Coupler Installed. Step 4c**

- d. Install the drive gear onto the coupler on the shaft of the MTH. See Figure 26 for a picture of this step.



**Figure 26: Drive Gear installed on MTH. Step 4d**

- e. From the EA-3000IC Hardware Kit, install the large washer onto the drive gear. Then install the smaller washer on top of the large washer. Next tighten the castle nut onto the shaft to 160-190 in-lbs<sup>4</sup>. Install the cotter pin through the castle nut and impulse coupled MTH shaft with the long end of the cotter pin

<sup>4</sup> AC 43.13-1B Table 7-1, 09/08/98

facing away from the MTH. Bend the long end of the cotter pin over the end of the shaft and the short end along the side of the nut. The drive gear is now installed onto the impulse coupled MTH shaft. See Figure 27 for visual install order of components.

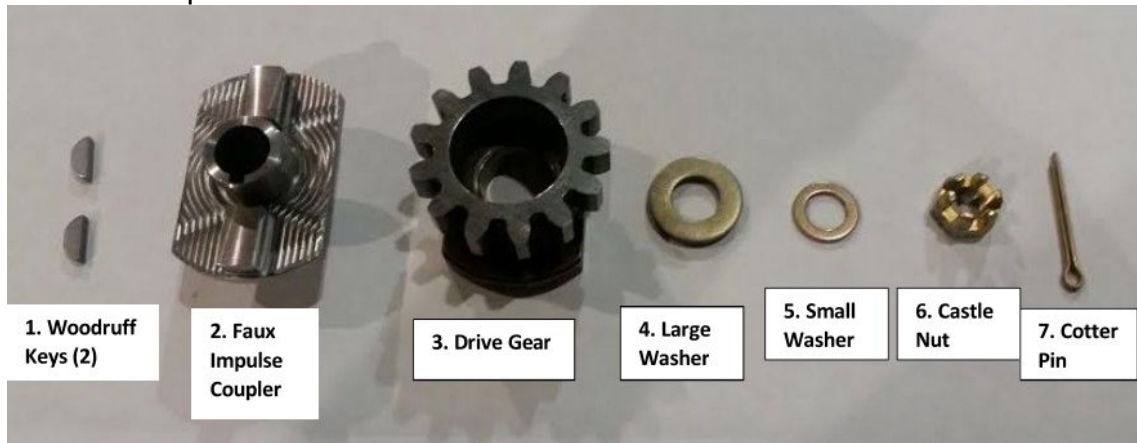


Figure 27: Install Order of Components to Impulse Coupled Shaft.

- f. Holding the Impulse Coupled MTH, insert the alignment pin in the alignment hole on the back cover (pin supplied with hardware kit). Slowly turn the gear on the front of the MTH until the alignment pin drops into a second hole inside the Impulse Coupled MTH. The impulse coupled MTH is now set to Top Dead Center (TDC) and the Impulse Coupled MTH shaft should not spin. Leave the alignment pin in the Impulse Coupled MTH and ready the engine for the Impulse Coupled MTH installation (next steps). See Figure 23 for an example.
- g. Clean magneto pad on the engine. Install new gasket on impulse coupled MTH.
- h. **VERIFY MASTER SWITCH IS OFF AND BATTERY IS DISCONNECTED.**
- i. Rotate the engine to Top Dead Center (TDC) for cylinder #1. This done by rotating the prop ***in the direction of the engine rotation*** until TDC is reached. Verify TDC using the timing marks found on the engine. Typically, the first set is on the fly wheel and the starter; they will line up at TDC; the second set may be another mark on the back-side of fly wheel which lines up with the engine case seam at TDC. If any of these indications are not correct, repeat this step until they are. ***Always rotate the engine in the direction that it rotates during operation.***
- j. Install the Impulse Coupled MTH into the proper magneto hole. Secure the MTH using the MAG holding clips referenced in step 2e and secure per engine manufacturer specifications.
- k. ***Remove the alignment pin.*** Failure to remove the MTH Alignment Pin may cause damage to the Impulse Coupled MTH, the engine, or both.
- l. P/N EA-3000IC or EA-3000LHIC is now installed and timed properly.
- m. Repeat these steps for the second engine on the airframe for installing either p/n: EA-3000IC or EA-3000LHIC on that engine.
- n. For Dual EIS installation, repeat steps 4a-4l and install the 2nd EA-3000 or EA-3000LH for each engine

## 5. Set-up & Installation of p/n: EA-24000(LH) MTH

- c. Retrieve p/n: EA-24000 or EA-24000LH MTH and the EA-24000(LH) MTH Hardware Kit.
- d. Holding the MTH, insert the alignment pin in the alignment hole on the back cover (pin supplied with hardware kit). Slowly turn the gear on the front of the unit until the alignment pin drops into a second hole inside the MTH. The MTH is now set to Top Dead Center (TDC) and the MTH shaft should not be able to spin. Leave the alignment pin in the MTH and ready the engine for the MTH installation (next steps). See Figure 28 for an example.



Figure 28: Installation of MTH Alignment Pin

- e. Clean magneto pad on the engine. Install new gasket on p/n: EA-24000(LH).
- f. **VERIFY MASTER SWITCH IS OFF AND BATTERY IS DISCONNECTED.**
- g. Rotate the engine to Top Dead Center (TDC) for cylinder # 1. This done by rotating the prop ***in the direction of the engine rotation*** until TDC is reached. Verify TDC using the timing marks found on the engine. Typically, the first set is on the fly wheel and the starter; they will line up at TDC; the second set may be another mark on the back-side of fly wheel which lines up with the engine case seam at TDC. If any of these indications are not correct, repeat this step until they are. Other safe methods for obtaining TDC may be used, such as observing the cylinder movement through the spark plug holes. ***Always rotate the engine in the direction that it rotates during operation.***
- h. Install the MTH into the proper magneto hole and connect correctly with the magneto drive gear retainer and cushions. Electroair recommends using new magneto drive cushions. See Figure 29.



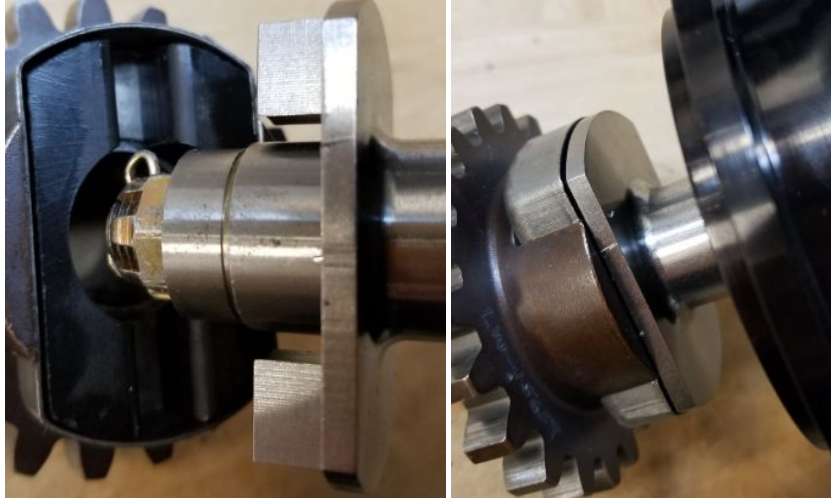


Figure 29: MTH Installation into magneto drive gear/cushions

- i. Secure the MTH using the mag holding clips referenced in step 2d and secure per engine manufacturer specifications.
- j. **REMOVE THE ALIGNMENT PIN.** Failure to remove the MTH Alignment Pin may cause damage to the MTH, the engine, or both.
- k. P/N EA-24000(LH) is now installed and timed properly.

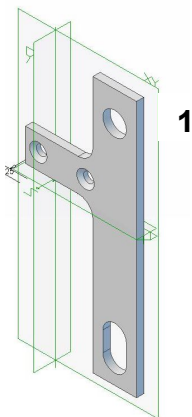
**6. Set-up & Installation of p/n: EA-9000A CSTW kit:**

- a. Retrieve p/n: EA-9000A CSTW kit. (if included with the EIS-41000 series kit).
- b. Access is needed to the crankshaft between the engine case and the prop flange. Refer to engine manufacturer instructions to remove those components necessary to gain access.
- c. Clean the crank area just in front of the crank shaft seal. **CAUTION:** The exposed portion of the crank shaft is tin plated. Electroair Acquisition Corp. recommends using a liquid cleaner/degreaser. Do not use an abrasive (like sand paper or scotch-brite); this will remove the plating. Refer to engine manufacturer's maintenance instructions for proper procedure.
- d. **Lycoming Installations (Magnetic Pick-Up Bracket Installation)**
  - i. Temporarily fit the CSTW on the crank with the trigger wheel (timing teeth) toward the engine case. Slide the CSTW toward the prop flange (Silver side of the CSTW to the engine case, black side to the propeller). Maintain a minimum distance between the engine case and CSTW of 0.100".

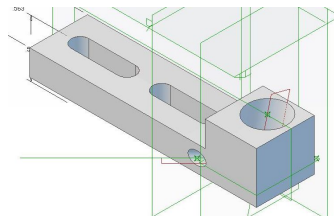


Figure 30: Typical installation of CSTW on a Lycoming 540 engine. Picture shows orientation of trigger wheel and typical bracket location. Please contact Electroair Tech Support if there are any questions about the assembly.

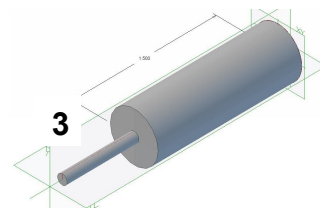
Figure 30



1



2



3

Figure 31: Components that make up the Lycoming CSTW Sensor Bracket; 1. Pick-Up Bracket; 2. Pick-Up Holder; 3. Magnetic Pick-up (Magnetic Sensor); hardware is not shown for clarity.

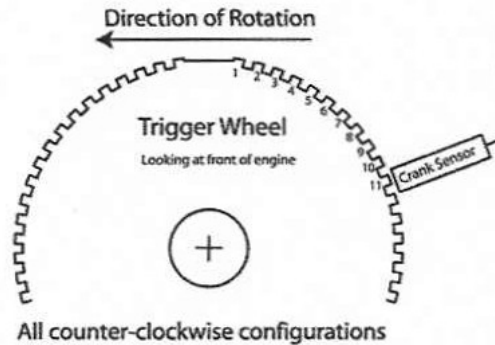
Figure 31

- ii. Temporarily install the pick-up Bracket Stand-Offs: Remove the forward journal bolt nuts and install the Bracket Stand-Offs supplied in the CSTW kit (see Figure 30); torque Stand-Offs to the same value as the nuts that were removed (300 in-lbs, per Lycoming manual).
- iii. Install Pick-Up Bracket using supplied socket head cap screws; torque screws to a value of 300 in-lbs. **NOTE:** Bracket may have to be removed to be able to install Pick-Up Holder; once bracket is in place and will not be removed, safety wire the cap screws in place.
- iv. Temporarily install the Sensor Holder on to the Pick-Up Bracket; leave the nuts loose enough so the Sensor Holder can slide back and forth to obtain the correct position.
- v. Position the CSTW so that the magnetic pick-up (sensor) would be oriented correctly on the timing teeth on the CSTW.
- vi. Rotate the CSTW and align the hole in the CSTW with the alignment tool (dowel/riquet assembly). Complete this by inserting the shaft of the pop rivet through the hole in the wood dowel. Place this assembly into the hole of the Pick-Up Holder (dowel/riquet assembly simulates a magnetic pick-up and pop rivet will serve as an alignment pin). Hold it in place.
- vii. While holding these pieces together, mark the position of the Pick-Up Holder on to the Pick-Up Bracket.
- viii. After marking the location of the Pick-Up Holder, remove the Pick-Up Bracket and Holder assembly; tighten the fasteners so the Pick-Up Holder is in the correct location on the bracket.
- ix. Re-attach completed magnetic Pick-Up Bracket/Holder assembly to the engine (install bracket assembly on stand-offs); tighten fasteners to the recommended torque values found in the engine overhaul specifications. **Verify that screws holding bracket to stand-offs have been secured using safety wire.**
- e. Verify that the master switch is off and battery is disconnected. Verify that the mag switch is off and the mag is properly grounded.



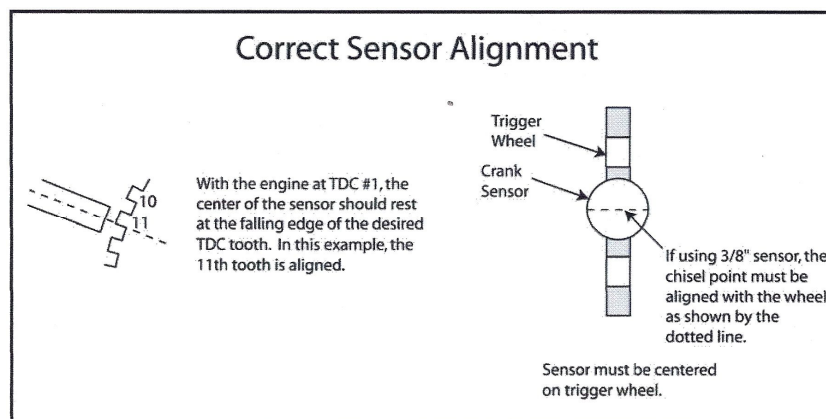
## **ALWAYS STAY OUT OF THE PROPELLER ARC!**

- f. Rotate the engine until number one cylinder is on Top Dead Center (TDC).
- g. Loosen the CSTW and rotate it until the alignment pin (remember the dowel/pop rivet assembly which is still in the pick-up holder) lines up with the hole in the CSTW. The alignment pin can be used to lock the CSTW position. **This should place the trailing edge of the 11<sup>th</sup> tooth past the two missing teeth** directly under the center of where the magnetic pick-up will go. Reference Figure 32 for sensor alignment and positioning.



**Figure 32: Crank Shaft Trigger Wheel Positioning**

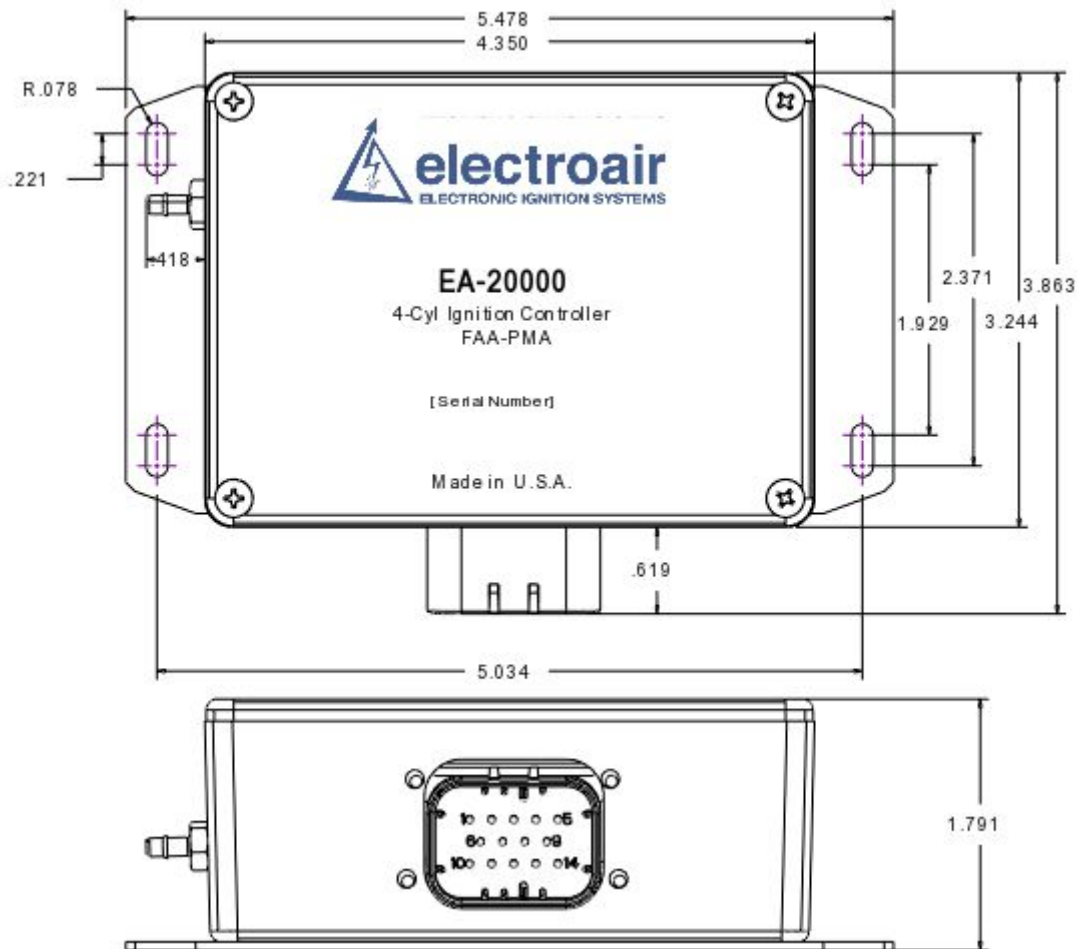
- h. Remove CSTW and apply Loctite (Loctite #242) to the crank shaft side of CSTW and to the two socket head cap screws.
- i. Carefully replace the collar to the crank shaft and line up using the alignment pin as a described in step g. The alignment pin will help hold the CSTW in position.
- j. Torque the cap screws on the CSTW to 20-25 inch-pounds. Be very careful that the gap between the two collar halves remains equal on both sides. If this gap is not held constant, the CSTW will not be concentric around the crank shaft and the timing pick-up will not function properly. **CAUTION:** Do not tighten the CSTW screws to the point that there is no gap between the collar halves. This means that the screws are over torqued, the aluminum collar stretched, and the CSTW will need replacing.
- k. Route the magnetic pick-up wire harness up the center of the engine case and then on top of the engine. Use cable ties as necessary to secure routing. **Do not route near spark plug wires. Do not tie wrap to ignition leads.**
- l. Remove the dowel/pop rivet assembly from the pick-up holder and install the magnetic pick-up. Using a feeler gauge or equivalent, set the gap to 0.024 inches. Once the gap between the timing teeth and the magnetic pick-up is set, apply a thin coating of Loctite #242 to the set-screws, insert them into the pick-up holder, and tighten them down. Remove the feeler gauge. **NOTE:** The tip of the sensor is a “Chisel Point”; this chisel must be positioned so that it is perpendicular to the plane of the trigger, or so that the chisel is parallel to the line of flight. See Figure 33.



**Figure 33: Correct Sensor Alignment**

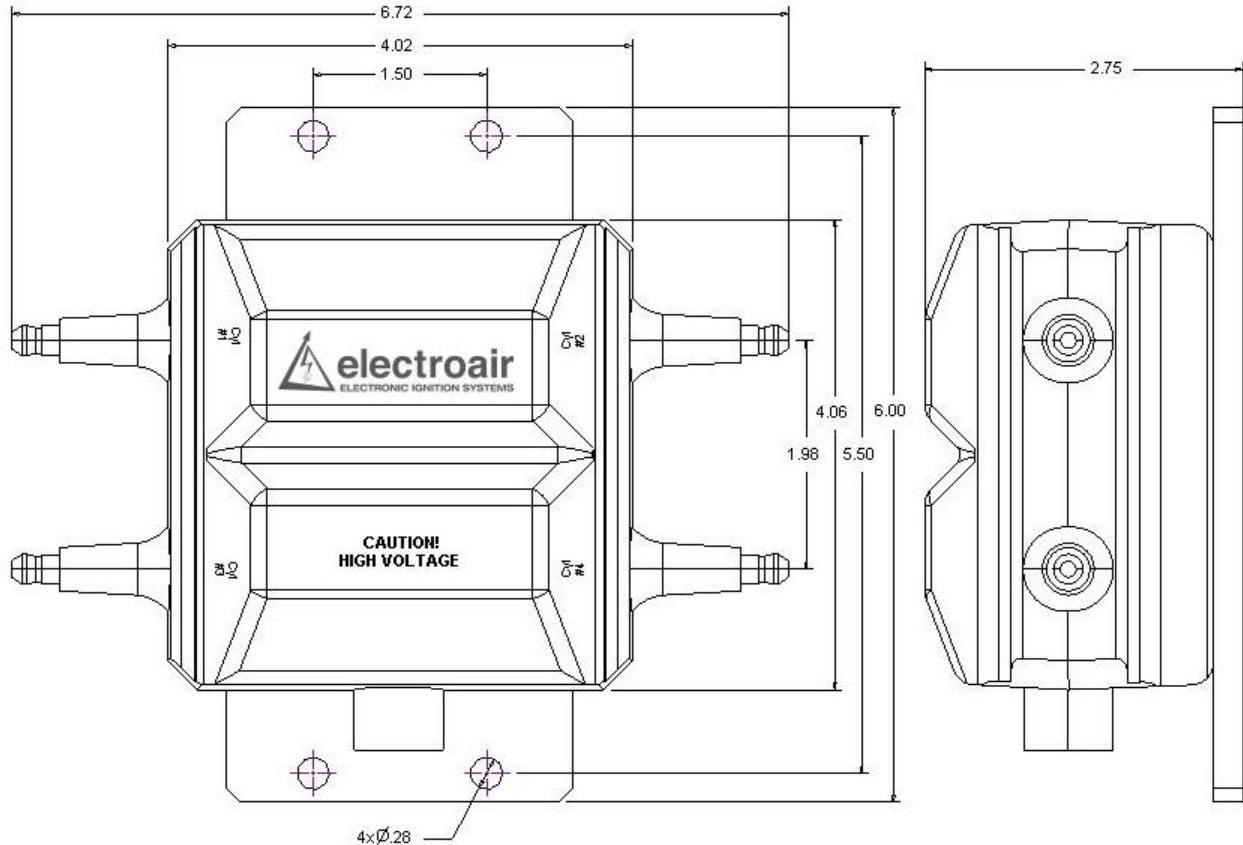
**7. Installation of p/n: EA-20000 EIS Controllers and p/n: EA-2000 Coil Packs:**

- a. **EA-20000 Installation:** Install both (four for Dual EIS) p/n: EA-20000 EIS Controllers where temperatures will not exceed 150°F. Electroair recommends that the EIS Controllers be mounted on the cool side of the firewall with the shortest practical distance from their respective coil packs for the wiring harness runs. Note: Some twin-engine airframes have open space inside the nose of the airframe. The controller could be placed on the nose side of the bulkhead which separates the cabin from the nose. Reference Figure 34 for controller dimensions.
- b. Use standard hardware to attach secondary ground wire from the exposed metal mounting hole on the EA-20000 to a competent airframe ground. A standard #6 screw will fit in the mounting holes.



**Figure 34: P/N EA-20000 Overall and Hole Dimensions**

- c. **EA-2000 Installation:** The coil pack is designed to be installed on the engine side of the firewall. Establish coil pack installation locations on both engine firewalls that will keep the spark plug wires as short as possible, keep clearance between the coil pack and other components, and not create maintenance difficulties in the future. Electroair strongly suggests that the Coil Packs be positioned so that the connector on the coil is facing straight down but can be positioned in any orientation if the installation requires alternate positioning. See Figure 35 for the Coil Pack Dimensions.



**Figure 35: P/N EA-2000 Dimensions**

- d. P/N EA-2000 comes with the mounting plate disassembled from the coil pack. This is done so the mounting plate can be used as a guide for easily locating mounting holes. When the mounting holes have been located, install each plate onto to its coil pack following the procedure below:
- i. Obtain the mounting plate, coil pack, six mounting screws, and Loctite #242 (included in the EIS kit box).
  - ii. Align the six clearance holes on the coil plate so that they line up with the six threaded inserts on the coil pack. Make sure that the countersink, on the plate, is facing outward.
  - iii. Apply a small drop of Loctite #242 to each of the coil mounting screws and install each screw through the plate to threads in the coil pack. Make sure that the plate is straight and tighten screws (recommended torque value is 20-

- 25 in-lbs<sup>5</sup>). **Note:** Try turning each screw a little bit at a time, instead of turning one screw all the way down, to help the plate align with the coil pack.
- iv. The black wire that is attached to the mounting plate should be attached to a competent airframe ground



**CAUTION: Prior to any drilling, verify that there is clearance from any components on both sides of each firewall.**

- e. After all considerations have been made regarding the placement of the controllers and the coil packs, drill the mounting holes and install all four components using standard AN hardware. **NOTES:**
  - i. To avoid any firewall cracking, place large washers between the firewall and fastening nuts to reinforce these contact points.
  - ii. For honeycomb firewall installations, consider placing internal screw grommets inside the firewall around the mounting hardware to help prevent damage to the honeycomb structure.
- f. For Dual EIS Installations, repeat steps 7a-7e to install each EA-20000 and EA-2000.

---

<sup>5</sup> AC 43.13-1B Table 7-1, 09/08/98

## **8. Connection of Manifold Pressure Lines:**

- a. Variable timing function using manifold pressure is optional. If variable timing is not desired or unable to be utilized, then the EA-20000 controller must be returned to Electroair for correct configuration. If variable timing is desired, proceed to step b.
- b. Verify that a manifold pressure lines exists from both engines. If one exists proceed to step d.
- c. If a manifold pressure line does NOT exist, then one will need to be installed. This is Electroair's recommended procedure.
  - i. Select an appropriate source for MAP on the engine. For Continental and Lycoming engines, an unused primer port is acceptable source for MAP.
  - ii. Remove the plug from the unused primer port. Verify the thread size going into the primer port or other MAP source (typically 1/8" NPT). Select an appropriate fitting (we recommend for a straight nipple AN816-2D; for a 90° nipple, use AN822-2D).
  - iii. Fabricate and attach aluminum hardline to the nipple now installed in spare primer port.
  - iv. Route hardline to firewall bulkhead fitting (we recommend for a straight fitting AN832-2D).
  - v. On the cool side of the firewall, from the bulkhead fitting, route a flexible hose to the controller and attached hose to the EIS controller (EA-20000/EA-21000). We recommend using Stratoflex p/n: 193-2 or Aeroquip p/n: 306-2 flexible hose. Use correct swivel fitting for connection to bulkhead fitting; use standard hose clamps to secure flexible line to EIS controller.
  - vi. Check new lines for leaks before proceeding. Correct leaks as necessary.
- d. Connect the manifold pressure line from the LEFT engine to the bulkhead connector on the EA-20000 controller that has been installed for the LEFT engine's EIS Kit. **WARNING:** The manifold pressure line must be connected to the engine the EIS is controlling. If the manifold pressure line is not from the correct engine, the EIS will not operate properly and could cause serious damage to the engine.
  - i. If a Manifold Pressure gauge is installed, a "T" fitting can be placed into the manifold pressure line that is feeding the Manifold Pressure gauge.
  - ii. The size of the bulkhead connector is 1/8 inch. Recommend Aeroquip 306 or Stratoflex 193 hose with 1/8inch ID.
  - iii. The manifold pressure line may be connected with either standard fittings or other appropriate fittings for this application, in accordance with F.A.R 43.13.
  - iv. Verify that all connections and lines are tight and secure.
  - v. If a Manifold Pressure gauge is not installed and a new manifold pressure line was created, connect that new line directly to the bulkhead connector on the EA-20000 using standard fittings.
  - vi. For Dual EIS, connect the manifold pressure line from the LEFT engine to both bulkhead connectors on each EA-20000 controller that have been installed for the LEFT engine.



- e. Connect the manifold pressure line from the RIGHT engine to the bulkhead connector on the EA-20000 controller that has been installed for the RIGHT engine's EIS Kit. **WARNING:** The manifold pressure line must be connected to the engine the EIS is controlling. If the manifold pressure line is not from the correct engine, the EIS will not operate properly and could cause serious damage to the engine.
  - i. If a Manifold Pressure gauge is installed, a "T" fitting can be placed into the manifold pressure line that is feeding the Manifold Pressure gauge.
  - ii. The size of the bulkhead connector is 1/8 inch. Recommend Aeroquip 306 or Stratoflex 193 hose with 1/8inch ID.
  - iii. The manifold pressure line may be connected with either standard fittings or other appropriate fittings for this application, in accordance with F.A.R 43.13.
  - iv. Verify that all connections and lines are tight and secure.
  - v. If a Manifold Pressure gauge is not installed and a new manifold pressure line was created, connect that new line directly to the bulkhead connector on the EA-20000 using standard fittings.
  - vi. For Dual EIS, connect the manifold pressure line from the RIGHT engine to both bulkhead connectors on each EA-20000 controller that have been installed for the RIGHT engine.

## **9. Installation of p/n: EA-4000 Spark Plug Harnesses:**

- a. Install the spark plugs that will be connected to the Electronic Ignition Systems. Electroair recommends using new aircraft spark plugs. If re-using the old spark plugs, make sure that they are clean.
  - i. **Optional:** Electroair has approved wide gap aircraft spark plugs for use with our Electronic Ignition Systems. These spark plugs are manufactured with the wider air gap Electroair recommends be used with the Electronic Ignition Systems. These Electroair spark plugs are not included in the standard EIS Kit. These plugs are only approved to be used with Electroair's Electronic Ignition Systems. The Electroair part numbers and descriptions for these plugs are below:
    1. **EARHB32E Massive Electrode Spark Plug:** This plug is Electroair's version of the standard RHM32E spark plug. The EARHB32E plug is manufactured with a 0.036 inch air gap. The EARHB32E spark plug can be installed on the engines that are approved for the RHB32E spark plug, but can only be operated by an Electroair EIS. Please contact Electroair or one of our distributors for current pricing and availability of this spark plug.
    2. **EARHB32S Single Fine Wire Spark Plug:** This plug is Electroair's version of the standard RHB32S spark plug. The EARHB32S is manufactured with a 0.036 inch air gap. The EARHB32S spark plug can be installed on the engines that are approved for the RHB32S spark plug, but can only be operated by an Electroair EIS. Please contact Electroair or one of our distributors for current pricing and availability of this spark plug.
    3. **EAREM37HE Massive Electrode Spark Plug:** This plug is Electroair's version of the standard REM37BY spark plug. The EAREM37HE plug is manufactured with a 0.036 inch air gap. The EAREM37HE spark plug can be installed on the engines that are approved for the REM37BY spark plug, but can only be operated by an Electroair EIS. Please contact Electroair or one of our distributors for current pricing and availability of this spark plug.
    4. **EARHM38SE Single Fine Wire Spark Plug:** This plug is Electroair's version of the standard RHM38S spark plug. The EARHM38SE is manufactured with a 0.036 inch air gap. The EARHM38SE spark plug can be installed on the engines that are approved for the RHM38S spark plug, but can only be operated by an Electroair EIS. Please contact Electroair or one of our distributors for current pricing and availability of this spark plug.
  - ii. For all other aircraft spark plugs, Electroair recommends opening the gap of the spark plugs to 0.028 - 0.036 inches. Electroair suggests using the REM37BY (or UREM37BY) spark plug because they are the easiest to gap. Refer to manufacturer's maintenance instructions on how to adjust gap. Check the engine application data to verify that these plugs can be used in the engine.



**CAUTION:** Be careful when gapping all other plugs than the REM37BY (UREM37BY) plug, because the outer electrode can become overstressed and break. If problems arise with plug selection, please contact Electroair ([sales@electroair.net](mailto:sales@electroair.net) or 248-674-3433).

- b. Each EIS Kit came with two spark plug wire bundles. Each bundle will make two spark plug wires (four wires for a single EIS). **Note:** The EIS Kit comes with EA-4000 REM spark plug hardware. If RHM or RHB spark plugs are being used, please contact Electroair for replacement hardware.



**CAUTION:** Since each assembly makes two spark plug wires, be careful when determining spark plug wire length.

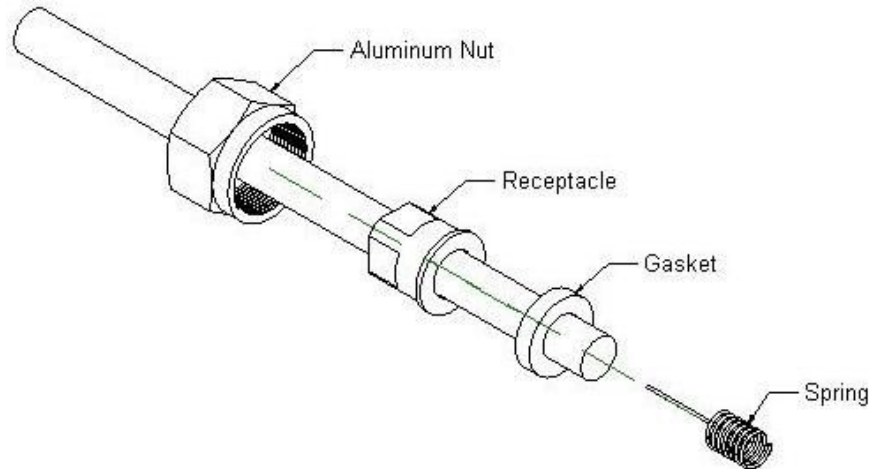
- i. Route the spark plug wire from the coil pack to the correct cylinder (See Coil Pack label for wire orientation) to determine the spark plug wire length. Make sure to keep spark plug wire routings away from exhaust pipes and sensor wires. Wires routed parallel to each other require a minimum of ¼ inch of separation.
- ii. Cut the spark plug wire leaving enough length to go three inches beyond the spark plug.
- iii. Slide the aluminum nut, receptacle, and gasket on the wire. See Figure 36 for the correct component stack-up.
- iv. The wire supplied is a spiral core wire with a non-conductive center. Insert the spark plug spring on the outside of the spiral core so that the spring 'tail' makes contact with the spiral core. The spring 'tail' should be felt as it hits the spiral core during the insertion.



**CAUTION:** do not install the spring tail directly in the center of the non-conductive material as it will not make contact with the spiral core.

**OPTIONAL:** ~1/8 inch of the ignition wire insulation may be stripped to expose the spiral core wire to make installing the spring easier.

- v. Verify continuity of the wires prior to install. Blue Wire (p/n EA-4090) resistance is 350 ohms/ft ±10%. Red Wire (p/n EA-4091) resistance is 5700 ohms/ft±10%.



**Figure 36: Spark Plug Wire Hardware Assembly**

**NOTE:** For assistance with Spark Plug Wire Assembly, you can go to <http://www.electroair.net/>. Under Tech Support and Troubleshooting there is a link to a video that provides a helpful demonstration for Spark Plug Wire Assembly.

- vi. To finish the connection, install the spark plug end of the wire first. This prevents the spark plug wire from twisting as the spark plug nut is tightened.



**CAUTION:** Do not over-tighten the spark plug nut as this may cause separation of the core of the wire. Torque the 5/8-24 spark plug hardware to 90-95in-lbs<sup>6</sup>. Torque the 3/4-20 spark plug hardware to 110-120 in-lbs<sup>6</sup>.

- vii. Repeat steps i through v for each wire
- c. Attach the other end of the spark plug wires to the coil pack at their appropriate coil tower. **NOTE:** When inserting the 90° boot over each tower on the coil pack, an audible “SNAP” should be heard when the wire is properly installed onto each tower. If this snap is not heard, remove the boot from the tower and repeat this step until this “SNAP” is heard.
  - i. Coil towers are numbered on the coil pack: 1, 2, 3, and 4. Because of the nature of the system, coil towers 1 & 2 will fire simultaneously and then coil towers 3 & 4 will fire simultaneously.
  - ii. For all Lycoming and Continental engines, hook-up the spark plug wires according to the following chart:

Coil Pack	Tower 1	Tower 2	Tower 3	Tower 4
Cylinder #	1	2	3	4

- iii. The coil towers should be oriented towards the same side of the engine as the cylinders – this should make spark plug wire hook-up easier
- d. For Dual EIS installations, repeat steps 9a-9c for each EIS kit’s spark plug wires.

<sup>6</sup> Bendix Ignition Manual

## 10. Connection of p/n: EA-22000T Twin Engine Wiring

### Harnesses:

- a. **Verify that the master switch is off and battery is disconnected.**
- b. The electrical connections that will be made are as follows:
  - i. Harness to p/n: EA-20000, EIS Controller
  - ii. Harness to p/n: EA-3000, EA-3000LH, EA-3000IC, EA-3000LHIC, EA-24000, EA-24000LH Mag Timing Housing (MTH) or EA-9000A CSTW
  - iii. Harness to Tachometer
  - iv. Harness to Switched Power & Ground for EIS Controller
  - v. Harness to p/n: EA-2000, Coil Pack
- c. **For Dual EIS Installation:** Refer to page 8 for Dual EIS Limitations and Requirements for Installation. Dual EIS refers to two EIS kits installed independently on one engine.
  - i. **Dual Electrical System Option:** Typically, there are two separate electrical busses on aircraft equipped with dual electrical systems. Using this option, wire one EIS to each separate electrical bus (steps 10.i.ix and 10.j.iii). Follow steps 10d through 10k for each EIS (follow steps twice per engine, once for each EIS). Electrical systems must be able to support a 12 volt, 1.5 amp, or 24 volt, 0.8 amp load for one EIS, and 12 volt, 3.0amp or 24 volt, 1.6 amp for two EISs.

**Note:** Twin-engine applications with dual electrical systems may share a common backup power source, independent of either engine's primary power source, which can provide electrical power after loss of power from both independent electrical systems.
  - ii. **Backup Alternator/Generator System Option:** Follow steps 10d through 10k for each EIS (follow steps twice per engine, once for each EIS). Select which EIS will be connected to the backup alternator (only one EIS per engine required). Attach that EIS to the backup alternator directly such that the EIS will continue to be powered by the backup alternator in the event of a primary electrical system failure. Attach the other EIS to the essential bus. Refer to backup alternator installation instructions for direct backup of electrical equipment to alternator. Backup alternator must be able to support a 12 volt, 1.5 amp, or 24 volt, 0.8 amp load for one EIS, and 12 volt, 3.0amp or 24 volt, 1.6 amp for two EISs.

**Note:** Form EAF-0526, Backup Alternator Load Analysis, must be completed, reviewed, and accepted before STC Authorization of Dual EIS install.
- d. Use the aircraft's existing wire runs as a guide for routing the EA-22000T Twin Engine Wiring Harnesses from the cabin to both wing mounted engines.



**CAUTION: Prior to any drilling, verify that there is clearance from any components on both sides of the firewall.**

- e. **NOTES:** The main harness is assembled so it can be installed through tight clearances such as a hole in the fire wall. A supply of terminations for switches,

circuit breakers, and the bus bar will be needed. A wiring diagram with pin-out information has been supplied at the end of this section for reference. Refer to AC 43.13 regarding the bend radii of wires.



**CAUTION:** Follow these wiring instructions very carefully to insure a correct hook-up of the EIS. Skipping ahead or taking short cuts increases the risk of an incorrect installation and either a poor performing EIS or the possibility of damaging equipment. Please contact Electroair with any questions.



**CAUTION:** Make sure that wires are separated away from the spark plug wires. High voltages going through the spark plug wires can interfere with signals going through sensor and power wires.

f. **Harness to p/n: EA-20000, EIS Controller:**

- i. Connect the wiring harness assembly to the EIS Controller. This is done by inserting the 14-pin female connector (C1) into the male header on the Controller. The harness is properly installed when the clip on the 14-pin connector is securing the connector to the header. Begin routing the various harness bundles and wires from here. Figure 37 shows the C1 connector.



Figure 37: C1 Connector

g. **Harness to p/n: EA-3000, EA-3000LH, EA-3000IC, EA-3000LHIC, EA-24000, EA-24000LH Mag Timing Housing (MTH) or EA-9000A CSTW:**

- i. Route the harness with the square BLACK three pin connector (C3) to the EA-3000, EA-3000LH, EA-3000IC, EA-3000LHIC, EA-24000, EA-24000LH MTH or EA-9000A CSTW.
- ii. From the already installed MTH, there will be a wire harness terminated with a female square BLACK three pin connector. See Figure 38 below.



**Figure 38: MTH and 3 Pin Female Connector**

- iii. Connect the (**C3**) connector from the routed harness to the connector on the MTH/CSTW. Verify that the connection is secure. Connectors should 'snap' together and be unable to fall apart from each other on their own.
- iv. Loop any excess wire and secure with cable ties.
- h. **Harness to Tachometer:**
  - i. The EIS has an optional electronic tach signal available and can be used with an electronic tachometer. If the signal is to be used, follow the next instructions.
  - ii. Go to the harness connector that is installed on the Controller.
  - iii. Obtain the 22 gauge BLACK wire, labeled "ELECTROAIR TACHOMETER", that is coming out of this connector at Pin 8.
  - iv. The Tachometer output signal is a 12V or 24V (dependent on aircraft system voltage) square wave with two pulses per revolution. **CAUTION:** Verify that the Tachometer or engine monitor system being used can receive the above signal before connecting and operating. Incorrect signal types can cause incorrect readings or potentially damage monitoring systems. Mechanical tachometers will not be able to receive the signal.
  - v. Route this BLACK wire to Tachometer or monitor system and install the lead as specified by the equipment manufacturer. Loop any excess wire and cable tie or clamp the loop to a convenient location that does not interfere with any components.
  - vi. If this output is not intended for use at this time, then this bundle should be looped and tied to an appropriate place. Alternatively, this wire can be trimmed out of the harness connector if this option will never be used.
- i. **Harness to Switched Power & Ground for EIS Controller:**
  - i. Go to the harness connector that is installed on the Controller.
  - ii. Obtain the RED wire that is coming out of this connector at Pin 6.
  - iii. Route the loose end of this RED wire to the existing ignition switch that was used to operate the magneto that is being replaced by this EIS, reference step 2d for switch clarification. **CAUTION:** Make sure that the ignition switch and EIS are used to control the same engine.
  - iv. Remove all existing wires that are connected to the airframe from this ignition switch.

- v. Determine the orientation of the switch when the switch is “OPEN” and when the switch is “CLOSED”. When the switch is “CLOSED” the EIS will be “ON” and when the switch is “OPEN” the EIS will be “OFF”.
- vi. If needed, rotate the EIS switch so that the EIS switch in its “OPEN” position is in the same orientation as the existing MAG switches in their “OFF” position. **NOTE:** When this step is complete, all of the ignition switches should be in the same position when they are “ON” and when they are “OFF”.
- vii. Trim and Terminate the RED wire from the EIS harness to this ignition switch.
- viii. Repeat steps i through vii for Dual EIS Installations.
- ix.
  - 1.) **Single EIS Installation:** Connect the panel mounted switch to a 2-amp breaker or fuse. Connect the 2-amp breaker or fuse to Essential Bus Bar. See Figure 20.
  - 2.) **Dual EIS Installation with Dual Electrical System:** Connect each panel mounted switch to a 2-amp breaker or fuse. For one EIS kit, connect its 2-amp breaker or fuse to one Essential Bus Bar. For the other EIS, connect its 2-amp breaker or fuse to the other essential bus bar. **Note:** Keep track of what power source is connected to each EIS. See Figure 21.
  - 3.) **Dual EIS Installation with Back-up Alternator:** Connect a panel mounted switch to a 2-amp breaker or fuse. For one EIS kit, connect that 2-amp breaker or fuse to the Essential Bus Bar. For the other EIS, connect the panel mounted switch to two separate current protection diodes. Current will need to flow into the EIS and not the other direction. From one of the diodes, connect to a 2-amp breaker or fuse and then to the essential bus bar. Connect the other diode to another 2-amp breaker or fuse and then to the back-up alternator. **Note:** Keep track of what power source is connected to each EIS. See Figure 22.
- x. The power for the EIS Controller has now been installed to be turned ON and OFF by the existing ignition switch.
  - i. Go to the harness connector that is installed on the Controller.
  - ii. Obtain the 16 gauge Black wire, labeled “ELECTROAIR GROUND”, that is coming out of this connector at Pin 14.
  - iii. Trim & Terminate the Black wire to a competent aircraft ground.
- xi. Repeat step x for Dual EIS installation.
- j. **Harness to p/n: EA-2000, Coil Pack:**
  - i. Route the harness with the round BLACK connector(C2) to the Coil Pack. This harness is terminated with a round plug type connector. See Figure 39 for how the harness should look. **CAUTION: There is a noise suppressor capacitor in the harness just below Coil Pack Connector (covered by heat shrink). Use extreme caution when routing this harness. DO NOT make sharp bends in the portion of the harness covered by the heat shrink. Make all bends past the heat shrink tube covered portion of the harness. This will prevent damage to the capacitor. Please call Electroair Tech Support if there are any questions.**





**Figure 39: Coil Pack Plug Harness**

- ii. Connect the connector from the harness to the mating connector on the Coil Pack.
- iii.
  - 1.) **Single EIS installation:** Route the unterminated end of the Red wire from the harness through a 10-amp breaker (fuses may be used as an alternative to the breaker) to the Essential Bus Bar. Trim and terminate as required. See Figure 20.
  - 2.) **Dual EIS installation with Dual Electrical System:** For each EIS, route the unterminated end of the Red wire from the harness through a 10-amp breaker (fuses may be used as an alternative to the breaker) to the same essential bus that the controller in the same EIS kit is connected too. Trim and terminate as required. See Figure 21.
  - 3.) **Dual EIS installation with Back-up Alternator:** For one coil pack, route the unterminated end of the Red wire from the harness through a 10-amp breaker (fuses may be used as an alternative to the breaker) to the same essential bus that the controller in the same EIS kit is connected too. Trim and terminate as required. For the other coil pack, route the unterminated end of the Red wire from the harness to two separate current protection diodes. Current will need to flow into the coil pack and not the other direction. From one of the diodes, connect to a 10-amp breaker or fuse and then to the essential bus bar. Connect the other diode to another 10-amp breaker or fuse and then to the back-up alternator. Trim and terminate as required. Note: This coil pack that is connected to the backup alternator should be in the same EIS kit as the controller that is connected to the back-up alternator. See Figure 22.
- iv. Loop any excess wire and cable tie or clamp the loop to a convenient location that does not interfere with any components (a location on the inside of the firewall is suggested).
- k. Figure 40 shows the Wiring Diagram for the EIS-41000T, EIS-41000TIC, EIS-41000TLH, & EIS-41000TLHIC. Both EIS kits for a Dual EIS installation will have similar wiring. The only difference between each installed EIS kit will be what essential bus or power source the EIS is connected too. **Note:** Single EIS installation means one EIS installed on an engine. Dual EIS installation means two EISs installed on an engine.

- i. **Single EIS installation on one or both (twin) engines:** The connections for C2-Pin 4 and C1-Pin 6 should be to the main essential bus (through 10A and 2A breaker or fuses). See Figure 20.
- ii. **Dual EIS installation on one engine with a single electrical system:** Connect C2-Pin 4 and C1-Pin 6 of one EIS to the main essential bus (through 10A and 2A breaker or fuses). Connect C2-Pin 4 and C1-Pin 6 of the 2nd EIS to a backup alternator and essential bus using current protection diodes (through 10A and 2A breaker or fuses). For twin engine aircraft, if the other engine has one EIS installed, the C2-Pin 4 and C1-Pin 6 connections can be made to either the main essential bus or the backup alternator.
- iii. **Dual EIS installation on one engine with dual electrical systems:** Connect C2-Pin 4 and C1-Pin 6 of one EIS to one electrical system (through 10A and 2A breaker or fuses). Connect C2-Pin 4 and C1-Pin 6 of the 2nd EIS to the other electrical system (through 10A and 2A breaker or fuses). For twin engine aircraft, if the other engine has one EIS installed, the C2-Pin 4 and C1-Pin 6 connections can be made to either electrical systems.
- iv. **Dual EIS installation on both (twin) engines with a single electrical system:** At least two separate backup alternators will be needed. Connect C2-Pin 4 and C1-Pin 6 of one EIS from each engine to the electrical system (through 10A and 2A breaker or fuses). Connect C2-Pin 4 and C1-Pin 6 of one EIS on each engine to the separate backup alternators and essential bus using current protection diodes (through 10A and 2A breaker or fuses). See Figure 41.
- v. **Dual EIS installation on both (twin) engines with dual electrical systems:** At least one backup alternator or backup electrical system will be needed. Connect C2-Pin 4 and C1-Pin 6 of one EIS from each engine to one electrical system (through 10A and 2A breaker or fuses). Connect C2-Pin 4 and C1-Pin 6 of one EIS on each engine to the backup alternator(s) using current protection diodes, or backup electrical system(s) (through 10A and 2A breaker or fuses). See Figure 42.

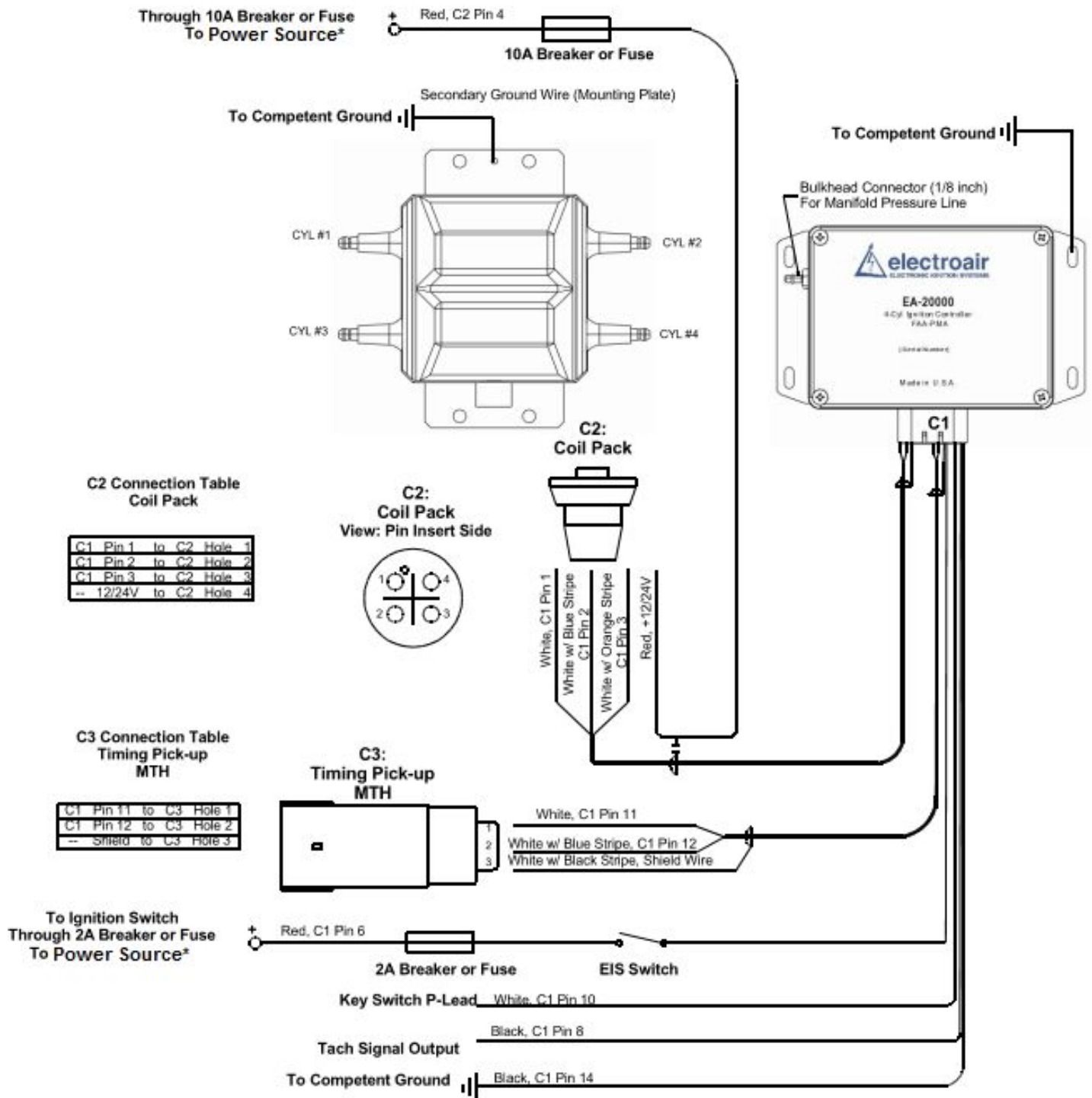


Figure 40: Wiring Diagram for EIS-41000T, EIS-41000TIC, EIS-41000TLH, & EIS-41000TLHC

\* Power Source: See step 10k and Figures 41-42.

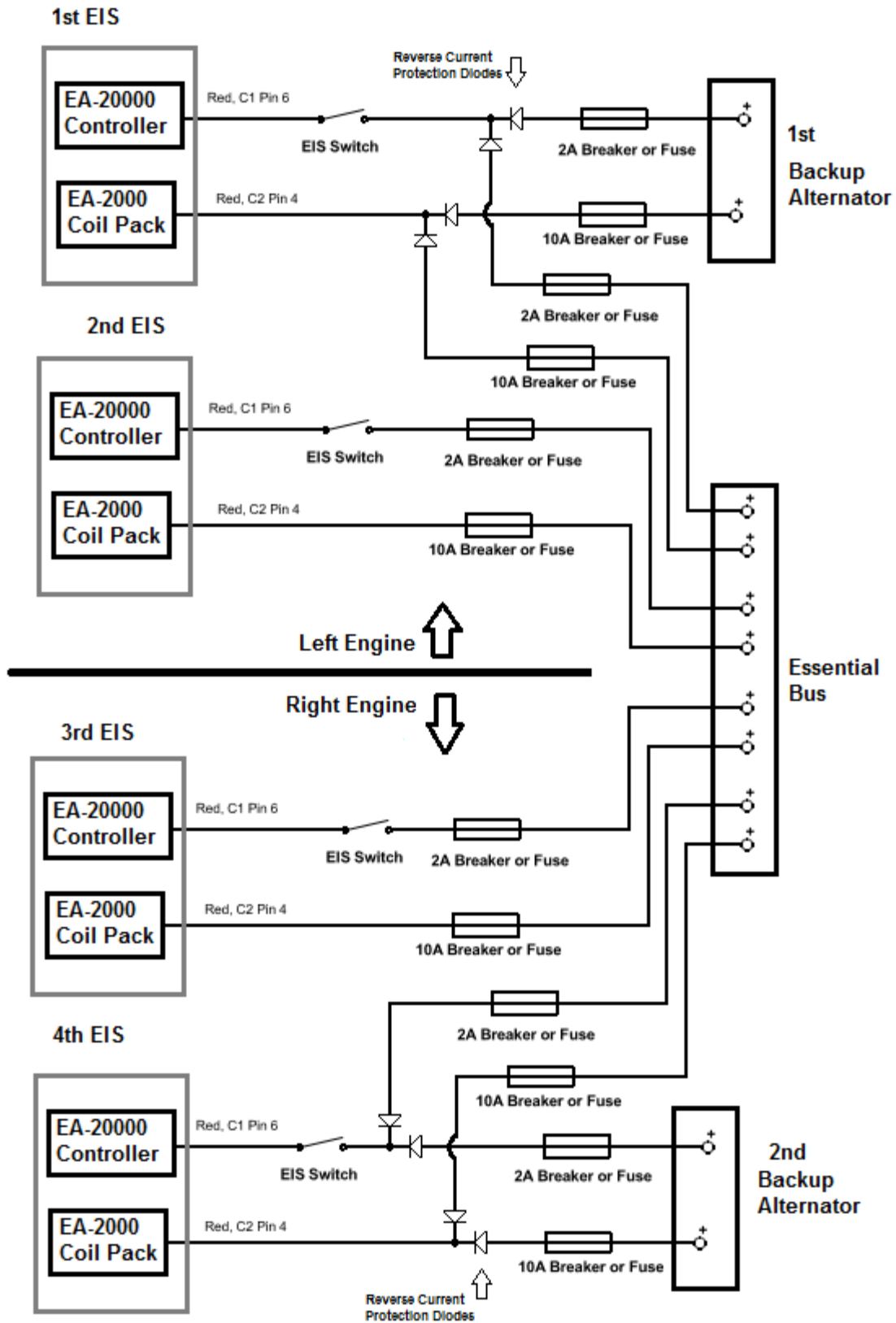
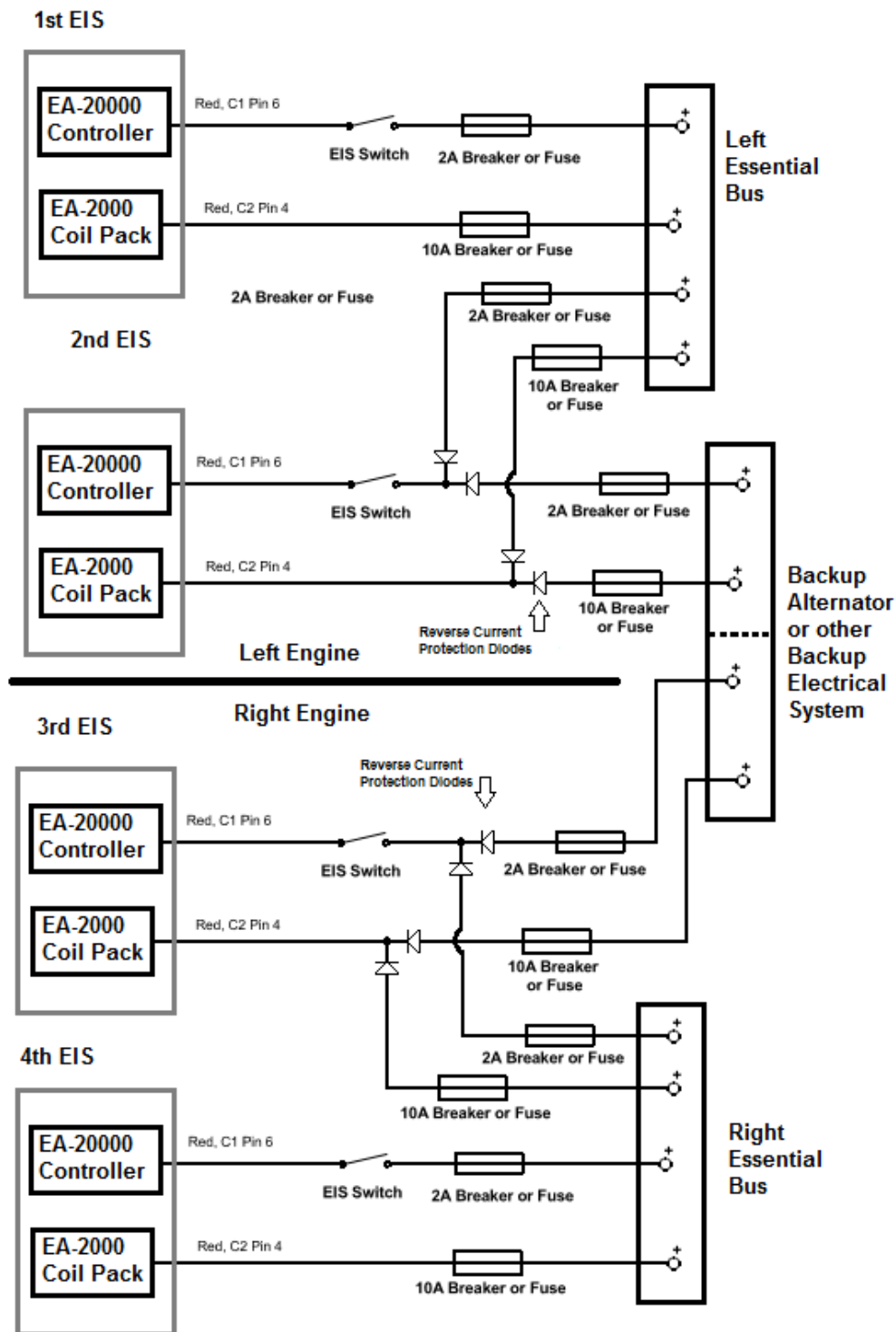


Figure 41: Twin Engine, Dual EIS, Single Electrical System Power Connections



**Figure 42: Twin Engine, Dual EIS, Dual Electrical System Power Connections**

- Backup power source may be shared or separate if they are independent of either engine's primary power source. See Dual Electronic Ignition Systems Limitations and Requirements section (page 8).

## **11. Final Installation Steps:**

- a. Calibration and Timing settings: The unit has been pre-set at the factory to a pre-determined base timing (base timing is always placarded timing for the engine). Contact Electroair (248-674-3433 or [sales@electroair.net](mailto:sales@electroair.net)) if it is felt that the unit is not performing optimally, or if that base timing needs to be adjusted.
- b. Re-attach and reinstall any connections or components that were removed or loosened during this installation.
- c. Secure all new wires, harness, connections and lines to prevent failures due to vibration.
- d. Connect battery connections and close any open circuit breakers.
- e. Recover all tools that may have been used (tools 'floating' around inside the airplane are dangerous).
- f. Verify backup power sources are capable of supplying the required load to connected EISs. Note: Form EAF-0526, Backup Alternator Load Analysis, must be completed, reviewed, and accepted before STC Authorization of Dual EIS install.
- g. Using the Aircraft Flight Manual Supplement, AFMS EIS-41000 Revision 09 or later FAA approved revision, for the EIS, perform a test run-up before flying.

**12. Installation Options Available from Electroair:**

- a. P/N: EAREM37HE. Electroair's Massive Electrode Spark Plug. This plug is Electroair's version of the standard REM37BY spark plug manufactured with a 0.036 inch air gap and has been approved for use with only Electroair's electronic ignition systems. These plugs come with the increased air gap Electroair recommends be used with our systems and eliminates the time and headache of re-gapping standard aircraft spark plugs. These Electroair spark plugs are not included in the standard EIS Kit. Please contact Electroair or one of our distributors for current pricing and availability of this spark plug.
- b. P/N: EARHM38SE. Electroair's Single Fine Wire Spark Plug. This plug is Electroair's version of the standard RHM38S spark plug manufactured with a 0.036 inch air gap and has been approved for use with only Electroair's electronic ignition systems. These plugs come with the increased air gap Electroair recommends be used with our systems and eliminates the time and headache of re-gapping standard aircraft spark plugs. These Electroair spark plugs are not included in the standard EIS Kit. Please contact Electroair or one of our distributors for current pricing and availability of this spark plug.

## Miscellaneous Information:

- For updated versions of this and other documents Electroair documents; refer to the company website: [www.electroair.net](http://www.electroair.net).

## Glossary and Abbreviations:

AD(s) – Airworthiness Directive(s)

AFM – Aircraft Flight Manual

AFMS – Aircraft Flight Manual Supplement

ALS – Aircraft Limitations Section

AML – Approved Model List

APU – Auxiliary Power Unit

BTDC – Before Top Dead Center

CFR – Code of Federal Regulations

CSTW – Crank Shaft Trigger Wheel

EIS – Electronic Ignition System

FAA – Federal Aviation Administration

Ignition Timing – is the process of setting the angle relative to piston position and crankshaft angular velocity that a spark will occur in the combustion chamber near the end of the compression stroke.

LOPC – Loss Of Power Control

MAG – magneto

MAP – Manifold Absolute Pressure

May/Should – an optional requirement

MTH – Mag Timing Housing

MEL – Minimum Equipment List

Must/Shall – a mandatory requirement

RPM – Revolutions per Minute

POH – Pilot's Operating Handbook

STC – Supplemental Type Certificate

TDC – Top Dead Center



## Revision Log:

Rev	Pages Affected	Date of Revision	Description of Revision	Approved by	Date of Approval
00			skipped number		
01			draft		
02			draft		
03		06/08/2011	Initial Release	JR	07/05/2011
04		08/26/2011	Revision based on DER report number ELA-1101	JR	10/07/2011
05		03/14/2012	Included instructions for installing the EIS-41000IC and EA-3000IC. Reworded P/N EA-6000 installation instructions for clarity, to address the use of fuses, and to address the use of non-rotary style ignition system. Also, added revision log at this time.	JR	04/06/2012
06		07/23/2012	Included optional use of Electroair spark plugs part numbers EAREM37HE & EARHM38SE, to this manual.	JR	07/25/2012
07		11/08/2012	Included installation instructions for twin engine aircraft EIS kits P/N: EIS-41000T, EIS-41000TIC, EIS-41000TLH, EIS-4100LTHIC	LRS	12/05/2012
08		07/15/2014	ECO 1116-0039	KP	12/15/2014
09		05/19/2015	ECO 1116-0118	KP	05/15/2015
10		01/23/2017	ECO 1019-0035	JMS	01/18/2018
11	2,3,9,10,22, 23,24,25,31,44,45,46, 47,55	04/26/2018	ECO 1019-0056	JMS	
12	1-3,5-6,8-14, 16, 18, 20, 21, 25, 27-31, 33-34, 36-39, 41-43, 46-50-51, 53	12/18/2020	SA09966CH-A: Electronic Ignition Timing Software Project	JMS	06/10/21
13	2-3, 7-8, 12-13, 15-16, 18, 21-33, 35-38, 41, 43-58	02/17/2022	Added Dual EIS Limitations and Requirements. Added Dual install instructions.	JMS	
14	11-13, 15, 17, 21-25, 32-34, 41, 44, 48-52, 59-61	03/28/2022	Added EA-24000(LH) and EA-9000A	JMS	
15	7-8, 15, 17-19, 24, 29, 35, 44-46, 51, 56, 62	11/21/2022	ECO 1019-0114	JMS	

16	25, 31, 37, 56, 62, 69	12/14/2022	Updated CSTW, Manifold Pressure, and Tach wire instructions for clarity.	JMS	
----	------------------------	------------	--	-----	--